

BASIC ELECTRICITY

by G. K. WILLECKE

BASIC ELECTRICITY

A COLLECTION OF INFORMAL LECTURES
ON ELECTRICAL FUNDAMENTALS
FOR ARC WELDORS

By

G. K. WILLECKE

Director of Research

Miller Electric Mfg. Co.

MILLER ELECTRIC MFG. CO.,

Appleton, Wis.

U.S.A.

Copyright 1954
MILLER ELECTRIC MFG. CO.

FIRST PRINTING, MARCH 1954

All rights reserved. This book, or any part thereof, may not be reproduced in any form without permission of the publisher.

Printed in the U.S.A.

PREFACE

This series of articles entitled "BASIC ELECTRICITY" was started in September, 1950, as a regular feature of MEMCO-NEWS, the house organ of Miller Electric Manufacturing Company. When the series was started, there was no thought to compiling all of the articles into a "text book" on "Basic Electricity." In fact, the basic concept behind the series was to "talk" rather informally about some fundamental electrical phenomena. A great number of requests came in for reprints of the articles—and time has not diminished the number of requests. The result has been this "collection of chapters."

In the light of the above concept, it is readily apparent that this booklet should be looked upon as a group of individual "fireside chats," and that a certain amount of discontinuity and some repetition should be expected. In the preparation of these "chapters" there was no basic outline and no comprehensive planning. They were prepared "off the cuff" and the main purpose was to create interest.

It is the author's firm belief that no one can be "taught" but that people must "learn" for themselves. The reader (or student, if you will) must have the "desire to know" in order to learn—and the purpose of the teacher is to "guide" that desire. For that reason, this collection of "Basic Electricity" articles is not an accumulation of facts, but a sincere effort on the part of the author to show the way to an understanding of electrical fundamentals.

This means, of course, that the reader has to "study" the material, rather than simply read the words. You will note that frequently I will admonish the student: "That although the wording may appear confusing, a little thought will make the meaning self evident."

If the following pages will help you get started on the right foot—will get you to think about some of the basic electrical concepts—will show you that "electricity" is not a difficult subject if you take it in easy doses—or if these pages will bring back some of the knowledge that has lain dormant in the back of your mind since you studied the subject in school, then the author will feel amply repaid. It has been fun to sit down and "think out loud" on the various subjects covered and it is the hope that you, too, will enjoy it.

G. K. Willecke

Appleton, Wisconsin
March—1954

TABLE OF CONTENTS

	Page
Chapter I. SOME FUNDAMENTAL CONCEPTS.....	7
Chapter II. AND SOME DEFINITIONS.....	10
Chapter III. SOME LAWS GOVERNING MOUSE MIGRATION.....	13
Chapter IV. FACTS AND FIGURES.....	16
Chapter V. DRAGNET.....	20
Chapter VI. MR. FARADAY'S CONTRIBUTIONS.....	23
Chapter VII. INDUCTIVE THINKING.....	28
Chapter VIII. THE TRANSFORMER.....	32
Chapter IX. LEADING UP TO SOMETHING.....	40
Chapter X. COSINE PHASE ANGLE.....	46
Chapter XI. THEORY AND PRACTICE.....	50
Chapter XII. JOULES AND WATTS.....	55
Chapter XIII. ONE WAY STREET.....	60
Chapter XIV. HOW MUCH?.....	67
Chapter XV. ELECTRONS AT REST.....	75
Chapter XVI. WHEN TROUBLE STRIKES.....	80
Chapter XVII. HIEROGLYPHICS.....	88
Appendix.....	92

CHAPTER I

SOME FUNDAMENTAL CONCEPTS

What is electricity? This is usually the first question that the student asks and he is quite disappointed when he is told that no one can answer his question. This seems rather strange too when one thinks of the thousand and one practical applications to which electricity has been put. We know how to control electricity. We know how to make it turn our motors. We know how to make it cook our food. We know how to make it carry our voices and pictures over thousands of miles. We know how to make it produce the heat to melt and to join metal. We know how to make daylight out of the darkest night. Still the fact remains that we do not know what it is.

The next logical question then might be: "Well, then, if we do not know what electricity is, what do we know *about* it?"

Here we can supply an answer. We shall go back in history and relive some of the experiences and contacts that Ancient Man had with this rather peculiar type of force.

About 2500 years ago Thales, a Greek, recorded a phenomenon that had no doubt been observed many centuries before his time, but had escaped the writers before him. Thales thought it interesting enough to record the fact that amber, when rubbed with silk, would attract small bits of lint and similar small objects. This was a strange power. It differed from the magnetic forces that had been observed in certain iron ores found in Asia Minor and yet, there was a strange similarity. It was a natural power that no one could explain at the time.

We can see the early Greek and Roman influence when we note that the Greek name for amber is ELEKTRON and the Latin name is ELEKTRUM. We can then conclude that the modern name for this great power, ELECTRICITY, comes from the Greek name for amber.

Now let us perform a few very simple experiments that, at the moment, seem to have very little bearing on our modern miracles produced through electricity. These experiments are simple and you can easily do them yourself or simply imagine that they are being performed.

Let's take a piece of hard rubber (a pocket comb will do very nicely) and rub it with a piece of wool cloth. We now note that the hard rubber will attract small bits of paper like the amber of the ancient Greeks. We say that the rubber is "electrically charged." Now suppose we take a table tennis ball and support it with a silken thread about 12 inches long. We now take the charged comb and touch the ping-pong ball. This will transfer some of the charge from the comb to the ball. Now we find that the comb will *repel* the charged ball. If we now take a glass rod and rub it with silk, it will also become charged but rather than repel the ball as the hard rubber object did, it will now *attract* the ball. A little clear thinking and detective work will enable us to deduce the following facts:

1. Evidently there are two kinds of "electrical charges" in existence.
2. Unlike charges attract and like charges repel.
3. Evidently, charges can be transferred from one place to another.

These three basic conclusions aided and abetted by certain mathematical laws and theorems form that basic field of knowledge known by the term "static electricity." It simply means electricity at rest. Had our knowledge of electricity been confined to electrostatics, we would not have the great industrial applications of electricity that we know today.

We are much more concerned with "current electricity" or electricity in motion; but an understanding of electrostatics is necessary to lay the foundation for a good electrical background.

Scientific research throughout the past has established the fact that *all* matter is made up of relatively few fundamental particles. One of these basic particles is the electron. It is, if you will pardon the loose word—"a tiny *glob* of basic matter carrying an electrical charge of the smallest unit quantity ever discovered." To enable us to identify this amount of charge again when we might meet it later on, we shall call it a *unit charge* and also since we discovered in our early experiment that there are two kinds of charges, we shall, arbitrarily call it *negative*. We could have called it black or white, high or low or anything else that we might have wanted to. There is nothing magic about the term. Further experiments have shown conclusively that it is these tiny particles that we call electrons, and that carry a unit negative charge, that are capable of being transferred from one place to another. It is these tiny particles that are rubbed off the wool cloth and collect on the hard rubber comb and give the comb a negative charge.

This, however, is not the complete story. All matter also contains particles of basic matter that are about 1800 times as heavy as the electrons but carry the same amount of the other kind of electrical charge which we, of course, have to call a *positive* charge. These more massive charges do not move as easily as the electrons, in fact, under normal conditions they stay put. Then too, in electrically uncharged matter the positive charges exactly balance the charges of the electrons and the object appears neutral. These positive particles are called protons.

We should now expect that if the hard rubber rod or comb of our experiment became negatively charged as a result of the rubbing with a wool cloth, the cloth should be charged positively since the electrons have been transferred to the comb. In other words, the comb now possesses an oversupply of electrons and thus carries a negative charge while the cloth has a shortage of electrons and because the protons now outnumber the electrons it carries a positive charge.

It must be kept in mind that the protons do not move. They are in the very center core of the atom, called the nucleus, and only in "atom-smashing" processes can the nucleus be disturbed.

Now, since like charges repel and unlike charges attract, it seems perfectly obvious that the electrons, when they collect in a crowd, do not like each other's company and try to go some place where the electron population is not so crowded. A positive charge is an ideal place for the electrons to try to move to, for there a shortage of electrons exists and they are much in demand. If the electrical "pressure" (potential) is great enough, the electrons may even jump through space. Any spark is an action of this type and of course, lightning is the grandest example of all. So whenever we see a spark, we know that electrons are on the march.

Another point should be considered in order to complete the picture of electrostatics. Different materials vary in their ability to hang on to their electrons when they are in the neutral state. This can be surmised from the fact that the electrons rub off the wool cloth rather than from the hard rubber. In the case of silk rubbed on glass, the electrons come off the glass onto the silk and leave the glass positively charged.

It appears that some materials, for example the metals, cannot be charged at all. This, however, is not true. The difficulty lies in the fact that metals usually do not hang on to their electrons very tightly and the electron deficiency is distributed throughout the piece of material.

Think of the situation something like this. Suppose we have a bowl of jello. We remove some of the jelled material in a certain spot. This will create a deficiency of jello in this spot since the rest of the jello in the bowl cannot flow into position. Thus a charge can be localized and maintained on materials called insulators. You might also note that it would take some effort to remove the jello in the first place.

Now let us fill the bowl with water and repeat the experiment. Here no local shortage can be produced since the rest of the water leaves its normal position and flows in to fill the vacancy created. Furthermore, if a pipe connected to a large water supply is attached to the bowl, we could not create a water shortage try as we might. This, then is the picture of the electrical conductor.

CHAPTER II

AND SOME DEFINITIONS

In the previous chapter, we developed the idea of positive and negative charges being created by the lack or excess of the basic electrical mobile particles called electrons. These particles carry a negative charge, are infinitesimally small and are more or less loosely bound to the various atoms making up all fundamental matter.

Remembering that like charges repel, and unlike charges attract, it is quite obvious that there would be a great tendency for electrons to move from a point of high negative charge (an oversupply of electrons) to a point that is positively charged and which is characterized by a great lack of electrons.

This tendency to move will become a reality if a suitable path is provided that the electrons can follow. We might recall now, from the first chapter, that conductors are those materials where the electrons are not bound very tightly to the respective atoms. It becomes apparent that a conductor placed between the two points of electrical charge mentioned above, will allow the electrons to move more or less freely from the negative charge to the positive charge. This, then, constitutes an electric current.

The fact that current flows from "minus" to "plus" is quite contrary to the popular notion. Benjamin Franklin is generally credited with making the statement that current flows from plus to minus. Since the electron theory was not developed at the time, and since the statement was purely arbitrary, we can see that it was a perfectly logical, although unfortunate error.

It really makes no difference in what direction we assume current flow; provided we do not get into electronic phenomena such as the theory of the arc and the vacuum tube. For purposes of consistency and ease in explaining certain phenomena, we will *subscribe to the statement that the electrical current flow is from minus to plus.*

To get an idea of the smallness of the charge of an electron, it might be of interest to bring the unit into line with every day terms. Most of us have at least a nodding acquaintance with the "ampere," the unit of electrical current. Actually, the ampere is another name for the expression "coulomb per second." This has its parallel in the term used for expressing liquid flow in "gallons per second." The coulomb then seems to be a unit of electrical quantity the same as the gallon is a measure of fluid quantity. If each electron is exactly the same as any other electron, then there must be a certain number of electrons that make up one coulomb. Also, if an ampere is "a coulomb per second" then that same number of electrons must flow past a point in the conductor every second if it is carrying "one ampere." This is very logical reasoning. Careful experimental and theoretical investigation has shown that this number is 6,300,000,000,000,000,000. In case you would like to talk about the number, it is 6.3 quintillion.

Note that nothing was said about how fast these electrons are moving along since we could have few electrons moving along pretty rapidly or we could have many electrons moving very slowly. Actually the electrons themselves are not moving very rapidly in normal circuits.

Now when we "use electricity" we do not "use up" the electrons at all. The electrons can be considered to be like very small droplets of water. They are capable of doing work because of the energy that is imparted to them. Water is not "used up" when it passes through a turbine, but it does give up some of its energy that it possesses because of the force of gravity. Electrons also possess energy of this kind which was imparted to them by the process of creating the difference in charge which actually caused the flow in the first place.

Let us now transgress for a moment to something that at first appearance seems to have no bearing on this picture. It is the basic theory of heat which is frequently referred to as "kinetic theory."

The smallest particle of matter which still retains all the characteristics of that particular matter is called a molecule. A few "giant molecules" have been seen through the electron microscope. Usually, however, basic molecules are so small that they can not be seen with even the most powerful microscopes.

If we now proceed to break up the molecule into still smaller particles we would find, after cataloging all the different particles found, that there actually are only about ninety-two or so different kinds. These basic particles are called atoms and they resemble very much our own solar system in miniature. It is these atoms that are made up of the protons and electrons (plus neutrons, positrons, mesons and other particles that have no particular part in our story of basic electricity) that we have talked about before.

These atoms that are the building blocks of all matter are in constant motion. In solids, the atoms move in a limited confined area, while in liquids they are considerably more free to move. In a gas, of course, there seems to be no limit to their motion other than the walls of the container. Now anytime that a particle is in motion it possesses a certain amount of energy (ability to do work) depending on the mass of the particle and the speed. We know from everyday observation

that a small particle (such as a bullet) traveling at high speed may possess more energy than a massive object traveling at a lesser speed. These atoms then must have energy depending upon their relative motion.

The greater the average energy of the atoms, the higher the temperature of the material. It makes sense now when we look back in our experience and note the fact that it is possible to heat a piece of metal by hammering it. Actually all we are doing is to jar the atoms and increase their speed.

The next step is quite easy to see. When we pass an electric current through a conductor, we should expect the passage of these tremendous numbers of electrons to disturb the atoms of the conductor and by knocking them about, cause them to speed up in their random motion. We should expect the temperature of the conductor to rise and this is what actually happens.

The better the conductor or the larger the conductor area, the less the disturbance caused by the passage of the electrons and the less heating. The poorer the conductor, i.e. the greater the opposition to the electron flow, the greater the heating effect for a given current.

The resistance to electron flow is measured in "ohms" and this is a basic electrical unit that must be mastered for an understanding of simple electrical phenomena.

We now have seen how the passage of an electric current can cause heating of conducting materials . . . a point that is the basis of the use of electricity in welding applications.

CHAPTER III

SOME LAWS GOVERNING MOUSE MIGRATION

Reviewing very briefly the fundamentals covered in the past two articles in this series, we can understand that current flow consists of passage of electrons (tiny negatively charged particles) from a location where an excess exists to a place where a deficiency is found. There must, of course, be a passageway for these electrons between the two charged points mentioned. Metals, because of the looseness of the electron bond, provide excellent paths and are therefore good conductors.

Now let us turn to some simple analogies. Imagine two areas, if you will, on a perfectly level surface. These areas are marked off with a sort of "elastic fence" made of rubber, let us say. In order to make it simpler to understand, let us identify these corrals by the letters "A" and "B."

Assume now, that areas "A" and "B" have been fenced off on a field heavily infested with field mice. If we now take a "mouse census" of the number of animals trapped in each corral the chances would be very good that we would have roughly an equal number in "A" and "B." They would be going about their normal business scurrying around in a more or less random fashion. Now suppose we would open a passageway between "A" and "B" and try to find a trend toward a migration in either direction. It is readily apparent that about the same number of mice would be going from "A" to "B" as from "B" to "A," and the net result would be no *net motion* in the connecting passageway.

This is exactly the situation as when we take two metallic objects in the uncharged condition and connect them with a conductor. There is no *net* electron flow and as a result no observable "current."

Now, how can we illustrate the condition that exists when we produce a condition so that a potential difference exists between the two metal objects and current actually does flow in the connection between the two?

Well, suppose we get to work and catch some of the mice in "A" and put them into the "B" corral. This will unbalance the condition we had before and create an over-population in "B" and a deficiency of mice in "A." Now if we open the passageway between the two, there will be a net travel of mice from the more densely populated area "B" to the other.

If we have done a great deal of work and have created (and are maintaining) a large unbalance, the rate of net travel of the mice will be relatively great. The greater the concentration becomes in "B," the greater will be "pressure" for the mice to get out and to travel to "A." Obviously, to maintain this greater pressure, more work will have to be done.

Let us consider one more point in the analogy before we go to the real electrical counterpart.

We could increase the rate of transfer from "B" to "A" by increasing the width of the passageway or in any other way, making it *easier* for the mice to travel through the passage. Making it a poorer "conductor" would, of course, decrease the rate of transfer.

Now let's keep the same reasoning and transfer our attention to electrons. Remember that "*the time rate of charge flow*" is called an electric *current*.

The unit is the ampere which is a short name for "one coulomb per second," and one coulomb is the charge of about 6.3 billion billion electrons.

Since we know that like charges repel, it is not too difficult to realize that we must do work, i.e., expend energy, in order to produce a concentration of electrons in a given place so as to produce a negative charge. The expended energy (per unit charge) is called the electrical potential, and it is measured in volts, named in honor of Alessandro Volta, an Italian professor.

Now this energy that is expended in creating the charge, makes its appearance in a force which tends to move the electrons away from this concentration. This is referred to as the "electro-motive force" and is commonly called "voltage." For practical purposes, it is not necessary to differentiate between potential and electromotive force and we will go along with this until later on when it becomes necessary to make a distinction, at which time we will clarify the point again.

Thinking back to our mouse analogy, it now is easy to see that the rate of charge flow (current) will be directly proportional to the electromotive pressure applied. This "directly proportional" term might appear to be confusing but what it means is simply that if we have a current of, let us say, 4 amperes flowing in a circuit where the voltage is 10 volts, then if we double the voltage, the current will also double. If we decrease the voltage to 5 volts, the current would be only one-half as great as before, or 2 amperes.

We can now make the positive statement that if all other factors remain the same, *the current in a circuit is directly proportional to the voltage*.

Now let us consider the effect of resistance on the current.

In a way, it is unfortunate that we speak more commonly of the *resistance* of a conductor than of the *conductance*. In other words, we

talk about how *poor* the conductor is rather than how *good* it is. Resistance is measured in ohms, in honor of the German scientist, Georg Simon Ohm, whose famous law we are now considering.

The ohm is defined as that resistance (or "current hold back effect") which allows a current of one ampere to flow in a circuit if the impressed voltage is one volt.

A little thought will now show that the current flow (if voltage is kept constant) will be inversely proportional to the resistance of the circuit.

The term "inversely proportional" simply means that if the resistance is *doubled*, the current will be reduced to *one-half*. Thus, if the resistance of the circuit is 10 ohms and a current of 5 amperes is indicated, increasing the resistance to 50 ohms (5 times as great as before) the current will be cut down to one ampere (reduced to 1/5 its original value).

These two rules, so simple and self-evident in themselves, are combined into a single statement and this is "Ohm's Law."

Now here is the complete statement: *In any electrical circuit the current is directly proportional to the electromotive force and inversely proportional to the resistance.*

Through proper choice of units, we can state the law mathematically as:

$$I = \frac{E}{R}$$

Where: I is the current
in amperes

E is the electromotive force
in volts

R is the resistance
in ohms.

As in any mathematical equation of three terms, any one term can be found if the other two are known. Thus:

$$E = IR \quad \text{and} \quad R = \frac{E}{I}$$

The use of this equation is not at all difficult. Try it right now on the following few problems:

- 1) A resistor of 15 ohms is connected across a battery having a voltage of 6 volts. What would be the current?
(Ans.: 0.4 Amps)
- 2) What value resistor would have to be used in a circuit if we wanted to limit the current through the resistor to 3.2 amperes on a line where the voltmeter reads 134.4 volts?
(Ans.: 42 Ohms)
- 3) If 2.3 amperes are flowing through a 15 ohm resistor, what is the voltage appearing across the resistor terminals?
(Ans.: 34.5 Volts)

CHAPTER IV

FACTS AND FIGURES

In the preceding chapter we discussed Ohm's Law, which is, no doubt, the most important fundamental principle in current electricity. Before we are able to make intelligent use of this useful law, we must develop one more idea and define one more unit.

We must go back to basic mechanical physics in order to set the stage for the proper understanding of the next concept, namely, "electrical power." The average man-on-the-street has a somewhat vague idea of what is meant by electrical power. He says that electrical power is the item that he actually "buys from the power company."

He might also be somewhat acquainted with the unit of measure of electrical power, the *watt*. He knows that his electrical appliances are rated in so many watts. If he is acquainted with the MILLER AEA-200-L unit, he knows that the machine, operating as a power supply, puts out 3 KW (kilo-watts) of electrical power. (Incidentally, the prefix "kilo" means 1,000. A kilowatt is 1,000 watts, a kilovolt is 1,000 volts and a KVA is 1,000 volt-amperes.)

A close look at the bill that the power company sends us each month brings out the fact that the charge is for so many "kilowatt-hours" rather than just kilowatts. Why the discrepancy?

Reviewing our fundamental terms in mechanics, we find that work is the product of force times distance. In other words, if we apply a force of, let us say, 10 pounds (a push or pull) and exert this force through a distance of 5 feet, then we are doing 50 foot-pounds of work. *Energy* is simply the ability, or capacity, to do work.

Now let us take a very simple example and see how these two terms can be applied.

Suppose I have a certain load that is to be moved upward a distance of 10 feet. Let's say that the load consists of 100 one-pound bags of coffee, (this has no significance--I'm not a hoarder!) If I would get my young son to do the job, he would carry a one-pound bag at a time

and make 100 trips and the job would be done. I would perhaps pick up the entire load and make only one trip. Now, each of us has done exactly the same amount of work. We each have expended exactly the same amount of energy. The difference, however, comes in when we consider the time angle. My *rate* of doing work was considerably greater than that of the boy. I say, therefore, that I am more *powerful*, because *power* is defined as the "time-rate of doing work." It should therefore be measured in units, such as "foot-pounds per minute" or some such unit as that. The practical unit in mechanics is the "horse-power" which is defined as the rate of "33,000 foot-pounds per minute, or 550 foot-pounds per second."

Now, what does all this have to do with electricity?

Energy, the ability to do work, may appear in several forms. We are familiar with the mechanical energy of the moving truck, the heat of fire and the electrical energy that we purchase from the power company. There is, however, no simple name or unit for electrical energy. (Actually in basic electrical theory, we do define the volt as a unit of work, i.e., one volt = one joule per coulomb. In this discussion we prefer to keep the volt as a unit of pressure, which although not strictly correct, is much simpler to visualize and serves the purpose much better in our elementary study of electricity.)

If we now take the ampere, the unit of current (rate of charge flow in coulombs per second), and multiply it by volts, we ought to get something akin to work per unit time. This product is called power.

The unit of electrical power is the watt which is equivalent to volts times amperes, or in formula form

$$W = EI \quad \text{where: } \begin{array}{l} W = \text{power in watts} \\ E = \text{voltage} \\ I = \text{current in amperes} \end{array}$$

Actually, the watt is also defined as one joule per second. The joule being a unit of work (similar but not equal to the foot-pound explained above) using the metric system of measurement. 746 watts are exactly equivalent to one horse-power which was defined before.

Now, let's get back for a moment to the bill that the power company sends us in which they charge us for kilowatt-hours or KWH. Now, follow these steps:

$$\begin{array}{l} \text{We can write kilowatt-hour as } 1000 \text{ watt-hours} \\ \text{or} \\ 1000 \text{ watt} \cdot 3600 \text{ seconds} \\ \text{or} \\ 1000 \frac{\text{joule}}{\text{second}} 3600 \text{ seconds} \end{array}$$

then the seconds will cancel out and we have left

$$3600000 \text{ joules}$$

and the joule is a unit of work or energy.

We are, therefore, paying the power company for *ENERGY* which does work for us.

If the above few paragraphs seem confusing with all the watts and volts and joules and horse-power and foot-pounds, just take it slowly and think about each statement. It isn't really too difficult.

Now that we have established the watt as a unit of electrical power, let's see how we can use it.

Take the case of the electric welding arc. Here we have a process where electrical energy is being converted into heat (and light). The arc voltage generally depends upon the material in the electrode and the length of the arc. A good operator generally holds a fairly constant arc voltage, let's say, around 25 volts. The amount of heat that is produced depends upon the current flowing in the arc circuit.

Does he want more heat? Increase the current! Less heat? Reduce the current! It is as simple as that. Remember that this is the *rate of heat* production. Obviously, the *total* amount of heat energy produced also depends upon the time.

We also note that the welding leads get hot; so do the primary leads, and of course, the transformer itself must be well ventilated to prevent overheating. Why?

The rate of heat production is measured in watts, i.e., volts times amperes. According to Ohm's Law, we know that we may write

$$E = IR$$

so if we take our previous equation $W = EI$

and substitute for E, we get $W = IR I$

or simply $W = I^2R$

This means that whenever we have a current flowing through a resistance, we have energy released in the form of heat. We pointed out in Chapter II how this comes about. This heat serves no useful purpose (except in electric heaters) and therefore is to be reduced to as low a value as possible.

There is nothing we can do about the current, for that is determined by the operating voltage and the power rating of the device. We can, however, keep the resistance R as low as possible. That means we should use wire and cable with as large a cross section as possible. Too often arc welders and spot welders are connected to lines with cables that are too small. The heat produced in the cable is then, of course, not available for welding and the output of the machine is reduced materially.

Note that the current term (I) in the equation is a squared term. This means that if the current is doubled through a resistance, the heat is not doubled but quadrupled (2 x 2). You can readily see why welding cable has to be so large (and incidentally, should be as short as possible). A welding current of 200 amperes through a cable resistance of only 1/10 of an ohm would dissipate 4 KW of welding power. Obviously, welding cable resistance is usually much lower than this value.

Resistors always carry a power rating which indicates the safe operating value of the unit. This simply means that if the unit is operated at or below this power rating, the heat will be dissipated rapidly enough so that the temperature does not rise above a certain safe value.

All electrical equipment, where the operator has any control over the operating conditions, is designed for a certain maximum safe power rating. In the case of welders, this is usually based on a 60% duty cycle over 10 minute periods. That means that a 200 ampere welder can be operated at the full 200 amperes for a 6 minute period and then allowed to cool for a 4 minute period and then the process can be repeated. If the machine is operated beyond this current rating, the duty cycle must be reduced. At lower than rated current, operation may very well be carried out on a 100% duty cycle basis.

CHAPTER V

DRAGNET

Before we start discussing alternating current phenomena, it might be wise to introduce another basic concept, namely, the idea of a magnetic field.

You recall that we established some time ago that an electric charge could be detected at a distance by placing a test charge in the vicinity and observing the mechanical force (push or pull) exerted on our test charge.

Let's illustrate this point with a simple scientific detective problem. This again, is one of those purely theoretical experiments and while it appears quite simple and obvious, it is very important.

Referring to the diagram below, imagine that we have an area shielded by a curtain through which we cannot see. In short, the shaded area as shown on the diagram is "forbidden territory."

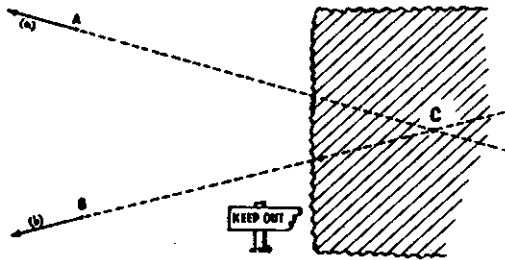

Fig. 1. The shaded area is "forbidden territory" for the observer at "A" and "B". We locate a charge at "C" without ever entering or seeing into the area beyond the curtain.

Now suppose we place a positive electrical test charge at point "A" and we find that a certain force is exerted on the test charge in the direction shown by the arrow (a). We carefully note the size of the force and plot the direction very carefully. Now we place our test charge at "B" and repeat the experiment, again noting carefully the magnitude and direction of the force acting on the test charge at point "B". We indicate that force by arrow (b).

This is all the information that we need for the time being and we can now go ahead and see what we can deduce from the given facts.

Since any mechanical force can be only a push or pull in a straight line, it is quite easy to see that the source of the force (a) must lie somewhere along the straight line of the extended arrow. This is shown in dotted form.

Likewise we can deduce that the source of force (b) must lie somewhere on the dotted line drawn as an extension of the arrow at "B."

If we now assume that the same "thing" causes both forces, then by simple geometry we can see that the intersection of the two dotted lines at "C" must give us the exact location of the source of the forces. Furthermore, since our test charge was a "positive" charge and the forces were acting *away* from point "C," we must conclude that a *positive electrical charge* is located at "C." This is obvious if we remember the first law of electrostatics—*unlike* charges *attract* and *like* charges *repel*.

Our detective work hasn't been too bad so far, but we can go still further.

Again making use of geometry, it is no trick at all to determine the distance of "C" from "A" (or "B" for that matter). Coulomb's Law, the fundamental law in electrostatics that tells us how the attraction and repulsion forces change with distance between charges, can now be used to determine the size of the charge located at "C."

You can see now that we have been able to determine the fact that a charge exists behind the curtain and furthermore have been able to tell its size, polarity and location with a great deal of certainty and accuracy.

A purist may object to this conclusion. He would say that the evidence only shows that a charge of said size and polarity *appears* to be located at point "C." He is perfectly correct, but any travel along this road of thought leads to philosophical discussions that are interesting but have no bearing on a practical understanding of electricity.

If the above points and the method are clearly in mind, we can now proceed.

All of us, I am sure, have a nodding acquaintance with magnetic forces. Every boy has no doubt used the very familiar "horse shoe magnet." We know that the magnet will pick up certain metallic objects that contain iron. These materials that can be attracted by magnetic force are called "ferro-magnetic" materials.

This magnetic force was thought to be entirely unrelated to the electrostatic forces that we have discussed above and in the first chapter of this series.

These magnetic forces were known for a long time and actually were thought to be of much greater importance. They certainly had the first practical application in the magnetic compass, the invention of which is attributed to several ancient people.

It seems quite surprising, when we study magnetic phenomenon, to find that we can build up the *same kind* of laws and rules for magnetic forces as we can for electrostatic forces. Mind you, these are *not* the same forces, nor are the laws the same, but we ought to consider them as parallel forces and parallel laws.

The first inkling that there was any connection between the two forces came quite accidentally in 1820. Hans Christian Oersted was professor of physics at the University of Copenhagen and during his lectures he usually demonstrated the non-existence of any connection between electricity and magnetism by placing a compass needle near a wire carrying an electric current. It is said that after one of these lectures some students came up to talk to him and he again demonstrated his experiment. To his surprise, he noticed that the needle did move. Reversing the current also changed the deflection of the needle. His further work led to the proposition that any current carrying conductor is surrounded by a magnetic field.

Let's now go back to the detective experiment that we performed at the beginning of this chapter. We will take a little "test compass" and place it in the region where we detected electrostatic forces. Try as we might we cannot detect any magnetic force.

But suppose someone behind this curtain would decide to move the charge from "C" to another position, then something would happen. We would, of course, be aware of the motion by noting the change in the electric field as we discovered it before. The forces acting on the test charges at "A" and "B" would change either in direction or magnitude or both. But here is the startling thing. AS LONG AS THE CHARGE AT "C" WOULD BE IN MOTION, we would also be able to detect a MAGNETIC FIELD in the region.

This magnetic field now is not in the same direction as the electric field, but is at right angles to it.

This can be made somewhat clearer by using the left hand thumb rule. Suppose you take your left hand and point the thumb in the direction that the electric charge is moving, (remember electric charges, electrons, travel from minus to plus) then the curled fingers of the hand indicate the direction of the magnetic field.

In other words, suppose you had a tiny magnetic test pole (north) and placed it near a current carrying wire, it would travel in a circle *around* the wire, while an electric charge would travel either toward or away from the wire.

The very important point to remember is that actually whenever we have a *changing* electric field, we have a magnetic field—and later on the converse of this statement can be proven—that whenever we have a changing magnetic field, an electric field is also present.

Asking which is more important or which comes first is a question in the "Which came first—the chicken or the egg?" category.

Thus there is established the very close and basic relationship between the electric and the magnetic field. It is the basis of the electromagnetic field. It is the basis of the electromagnetic wave theory and the underlying principle of all alternating current phenomena.

Would it not be for this relationship we would not have the transformer, the motor, the generator, radio and other electrical gadgets so indispensable to our everyday lives.

Now we are in a position to treat alternating currents intelligently and in the next chapter we shall start with the alternating current generator.

CHAPTER VI

MR. FARADAY'S CONTRIBUTIONS

In the last chapter, we discussed the basic relationship between the electric (electro-static) field and the magnetic field. We showed that a moving electrical charge will set up a magnetic field in the surrounding space. A stationary charge on the other hand, does not produce any magnetic effects, and the important point of Chapter V was that "*a changing electric field produces a magnetic field.*"

It must be understood, that as clear as the statement appears to us now, it was not as clearly stated or understood at the time of Oerstedt and Faraday. The simple fact, understood by scientists at that time was that "a current produced a magnetic effect."

Michael Faraday, one of the great shining lights in the history of physics, started a series of well-planned experiments back in 1831 that gave us most of our modern knowledge about induced electric currents.

It might be of interest in passing to mention that Michael Faraday (1791-1867), a bookbinder's apprentice in his early years, became so interested in the scientific books that passed through the bindery that he decided to make science his life work. He became an assistant to Sir Humphry Davy and then became so well known in his own right that few men in the annals of science have ever been offered greater honors, and modestly refused these honors, than Faraday.

It was Faraday who discovered the very important fact that if a wire carrying a current is suspended freely in a magnetic field, this wire can be caused to move.

We may ask: "Wasn't this Oerstedt's discovery?" Actually, Oerstedt showed that a *magnetic compass needle would move* if brought near a current carrying conductor. Faraday showed that the *wire would move* if brought into a magnetic field.

Here then, was the start of the modern electric motor. Combine Faraday's discovery with Oersted's work and you have the complete theory of the method of converting electrical energy into mechanical energy.

It was perfectly obvious that Faraday and others of the time, should make a very serious attempt to see if a conductor, placed in a magnetic field, would have a current flowing in it. In other words, will it be possible to produce an electric current with magnetism? The problem had been tackled by many scientists and each time they had come up against a stone wall.

Finally, Faraday made the most startling discovery—a current could be produced in a coil of wire ONLY if, and while, the magnet was in motion. This was the key to the problem. There had to be relative motion between the magnetic field and the conductor. Notice that the term "relative motion" appears in the statement. It makes no difference whether the wire is stationary and the magnetic field is moved over the wire or whether the wire is moved through the magnetic field. In either case, a current is "induced" in the wire.

In order to be absolutely correct, we should say that a voltage is set up across the ends of the wire, so that this "induced electro-motive force" causes a current to flow. This point can be made clearer if we look at the little sketch appearing in figure 2.

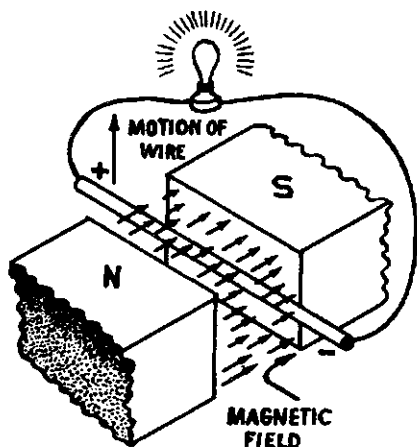

Fig. 2. The basic experiment to show Faraday's great contribution. The wire is moved so that the magnetic lines of force are cut at right angles.

Suppose we place a straight wire as shown between the pole faces of a magnet. The magnetic field (from north to south) is shown with the many small arrows. If the wire is now moved upward, a positive charge will appear at the far end as shown and a negative charge will appear at the near end. If we now complete the circuit, as shown with the smaller wires and the light bulb, then a current will flow in the circuit and cause the bulb to light.

Note the significance of this. We do mechanical work by moving the wire, and as a result we "generate" electrical energy.

If we replace the bulb with a battery or some other source of electrical energy and cause a current to flow through the wire, then,

of course, the wire will move. If the reaction of the current flow is as shown in the diagram, the wire will move downward.

Here, then, we are using electrical energy and converting it to mechanical energy.

You now have the basic underlying principles of the electric generator and the electric motor.

It should come as no surprise then that some generators can be operated as motors and vice versa.

Let's now take a closer look at the generator and see what is meant by an alternating current.

Referring to figures 3 and 4, try to visualize what happens when the loop is rotated in the magnetic field. The four position diagrams are labeled A, B, C and D for easy reference. The loop, shown in cross-section, is being rotated in the direction shown by the curved arrow.

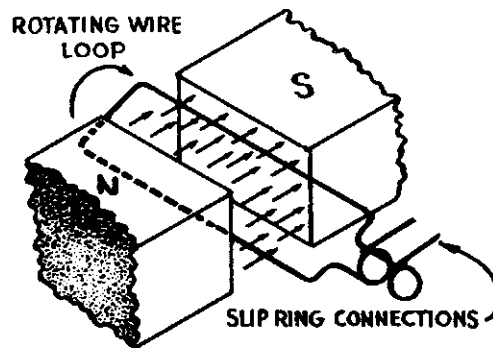

Fig. 3, right. Basic generator, or alternator, design principle.

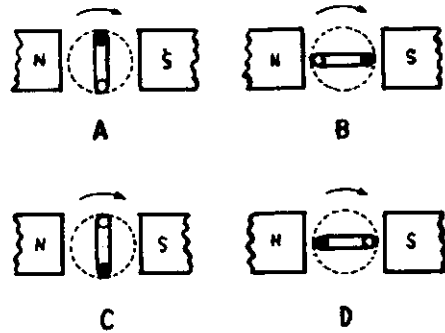

Fig. 4, left. Using a cross-section of the rotating loop of figure 3, the four reference positions are shown. To make identification easier one of the wires is shown black and the other white.

Now note that in position "A," the two sides of the loop are moving parallel to the magnetic field. No magnetic lines are being cut and thus no current is being induced in the loop. The current is zero.

In position "B," the coil has turned through 1/4 turn and now the wires are moving at right angles to the magnetic field and the most lines are being cut. This means that the current is maximum in one direction.

In position "C," the loop has now turned 1/2 turn and again the motion is parallel to the field and the current again is zero.

In position "D," the wires again are cutting the maximum mag-

netic lines of force and the current is again maximum BUT in the OPPOSITE direction as in position "B."

Continuing on to position "A" completes the cycle.

If we now apply a little knowledge of geometry and trigonometry, we can determine the rate at which the lines of force are being cut (assuming, of course, a uniform magnetic field), at any position of the cycle. If we plot the current vs. degree of rotation, we get the familiar sine wave graph as shown in figure 5.

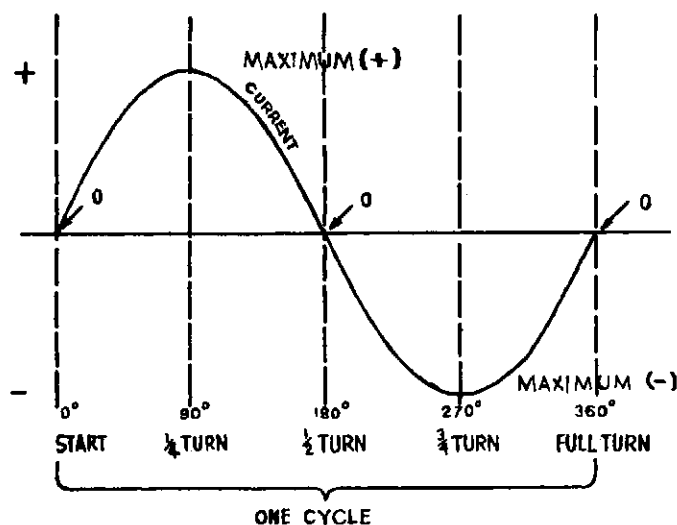

Fig. 5. Graph showing induced current in basic alternator. The dotted lines correlate the loop positions of figure 4 with the instantaneous value of current.

The electron motion in the circuit, in which we say alternating current is flowing, is back and forth, first in one direction then in the other.

During one complete cycle (one revolution of the generator coil) the electron flow is first in one direction with a gradual build-up to maximum during the first quarter cycle. During the second quarter cycle there is a decrease back to zero, while the third quarter cycle sees a build-up, but in the opposite direction.

During the last quarter cycle the electron flow decreases and drops to zero and then the whole process is repeated.

When we speak of 60 cycle A.C., we simply mean that 60 of these complete operations take place every second. Actually, then, there are 120 intervals every second (2 for each cycle) when the current is zero. 60 times per second, the positive maximum is reached and 60 times per second we have a negative maximum.

Most electrical power is distributed in this country as 60 cycle A.C. There are some 50 cycle, and some 25 cycle installations in this country, although these frequencies are encountered in other countries much more frequently.

Incidentally, we might point out that in most cases, equipment designed for 60 cycle operation will operate fairly satisfactorily on 50 cycle lines with a slightly decreased operating efficiency. (This is not true with electric clocks or synchronous motors.) This is the reason that much equipment is labeled 50 60 cycle operation.

We are now ready to consider the electrical transformer a device that can be considered an electrical generator being driven by electrical energy rather than mechanical energy.

May I point out again that if the various statements, appearing in these articles, appear confusing and difficult to understand, a little study will clear up most points.

CHAPTER VII

INDUCTIVE THINKING

The important fact brought out in the last couple of chapters was that anytime a *changing* magnetic field exists there appears at the same time a changing electric field at right angles to the direction of the magnetic field. It should be remembered that the electric field exists whether there is a conductor there or not, but if we place a wire (or any conductor) in the space where the field exists—then we can cause a current to flow in that wire.

This principle must be clearly understood before we can talk intelligently about the practical applications of electromagnetic induction.

In Chapter VI, we showed that by taking a conductor and moving it through a steady magnetic field, we could induce a current in that conductor. We indicated that it made no difference whether we moved the wire through the magnetic field or whether we moved the magnetic field past a stationary wire. Relative motion between the two—the conductor (usually in the form of a coil) and the magnetic field is the important point. We spent quite a bit of time analyzing the “rotating loop in the steady field” machine. It takes no great amount of imagination to see that we could have kept the loop stationary and *rotated the magnetic field* to get the same results. The same analysis would still apply.

In fact, the term "*rotating field type generator*" refers directly to this principle. A good example of this type of machine is the generator used on the engine driven MILLER model AEA-200 and the others of this generator series. Here, the field coil which is energized by direct current from a separate exciter, is rotated. The armature coils, in which the current is being induced, are stationary. An advantage of this type of generator is that the heavy generated power does not have to pass through the slip ring or commutator assembly with their associated brushes and leads. All of the power generators used to provide the commercial power distributed by the utilities, are of this type of construction.

There is, however, one other possibility of accomplishing the same job and that is to produce a changing magnetic field directly *without* any mechanical motion whatsoever. This is the basic underlying principle of the transformer.

The most convenient way that a changing magnetic field can be produced is by using alternating current. Of course, we could use mechanical interrupters or reversing switches to change the current and thus produce a changing magnetic field, but this method has limited applications.

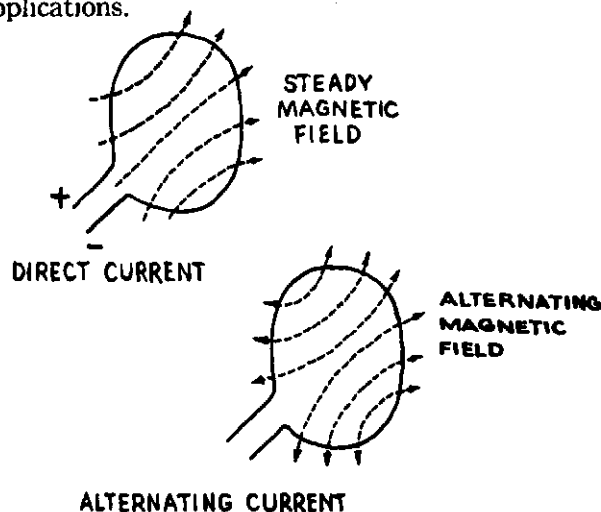

Fig. 6. Magnetic fields produced by direct current and alternating current, flowing in a single turn loop.

Referring to figure 6, we have a simple single turn coil. If we pass direct current through this coil, we shall get a steady magnetic field. Since the magnetic field produced depends upon the strength and direction of the current, we can see that any change in the current will result in a change in the magnetic field.

From the last chapter, we see that an alternating current is continuously changing in direction and in strength. So if alternating current from an external source is fed to the coil, we would produce a constantly changing magnetic field, as indicated in the diagram.

Now, let's go one step further. Suppose that we now place another coil close to the first one so that the magnetic field produced by the first or primary coil, links with the other coil as seen in figure 7.

Let's connect a current detecting device, such as a light bulb, in the circuit of the second coil. If we apply D.C. to the primary coil by closing the switch S, the magnetic field would be changing only during the instant that the switch is being closed. Then the field would be steady until the switch is opened to break the circuit when the collapsing field would again represent a changing magnetic field.

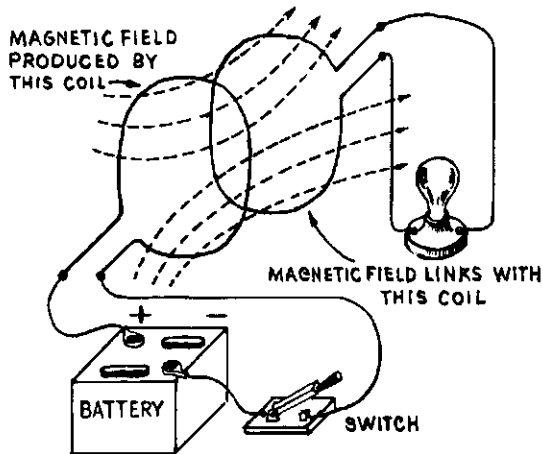

Fig. 7. Two "coupled" single turn loops. The loop connected to the battery produces a magnetic field while the loop connected to the lamp "generates" a voltage.

Current would be induced in the secondary coil when the switch is *closed* and again when the switch is *opened*. Our light bulb should then flash when the primary switch is operated. A flash when the switch is *closed* and another flash when the switch is *opened*.

Now, if we could flip this switch quickly enough, we could make the flashes of the light bulb so fast that we could not follow them, and the bulb would appear to be lit continuously.

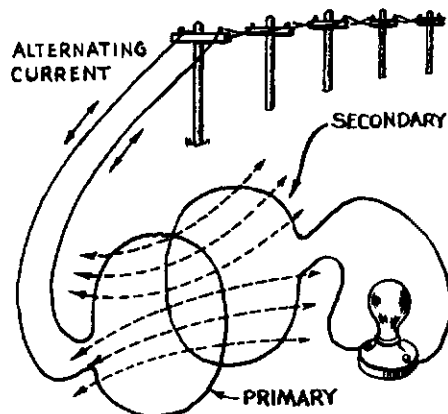

Fig. 8. The elementary alternating current transformer.

Again, as a sidelight, we might point out that this is the principle of the induction coil where a vibrating contact is placed in the primary circuit. Some of you might remember the old Ford Model T spark coils with their vibrating contact on top. Our modern ignition systems use breaker points to interrupt the primary current and produce the voltage in the secondary of the coil that caused the spark.

It is, however, much simpler as was pointed out before, to use alternating current on the primary and produce a continuously changing magnetic field without any mechanical switching as in figure 8.

Then since the magnetic field follows the primary current, and *induced* current in the secondary follows the changing magnetic field, it is apparent that we can effectively transfer A.C. current from one winding to the other.

This, then, is the A.C. transformer. It consists of a winding called the primary which is connected to a source of alternating current, and a secondary winding in which the alternating current is induced and this winding is connected to the load.

A welding transformer with identified windings is shown in Figure 9.

You might almost think of it as a combination motor and generator without the mechanical intermediate step. Current is "generated" in the secondary winding exactly in the same manner as in the generator discussed in the preceding chapter.

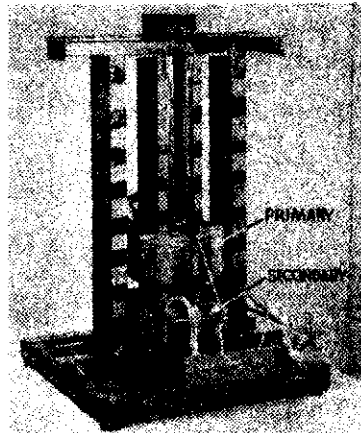

Fig. 9. A typical "moving coil" transformer type arc welder. Primary and secondary are labeled. In this construction the primary is the movable coil.

A magnetic field is produced by the primary in exactly the same way as the windings of the motor.

In the case of the motor, mechanical energy is produced which the generator uses to "generate" electrical energy. The transformer leaves out this intermediate step and it is not at all surprising then, that transformers can be designed to have exceptionally high efficiencies. Some transformers have been built that have efficiencies very close to 100%.

This is only the beginning of the "transformer story" and the next several chapters will go into more detail and discuss the different types and applications.

CHAPTER VIII

THE TRANSFORMER

In chapter VII, we led up to the basic principle underlying the transformer. We attempted to show how it was possible to “transform” electricity from one circuit to another without any actual contact between the circuits. We showed that the transformer could very well be likened to a motor and generator connected without benefit of mechanical connection. Let us now consider some of the details of transformer design so that we can approach the problem of specialized transformers a little more intelligently.

Remember now, in the last chapter, we pointed out that the purpose of the primary winding is to produce the changing magnetic field that is to link with the secondary windings and induce a voltage in this secondary. Quite obviously, there must be a “magnetic connection” between the two windings or else the transformer cannot function. The relationship between the two windings is referred to as the “coupling” between primary and secondary. In order then, to get all of the changing magnetic flux (produced by the primary) to link with the secondary, we should place the two windings as close together as possible. In technical language, we make the coils as “closely coupled” as possible. (We are now assuming, of course, that we are after the “perfect” transformer.)

No matter how closely we couple the windings, we still cannot get all of the flux to interlink. It ought to be possible, however, to provide a guide for the magnetic flux so that the amount of stray magnetic field is made as small as possible.

There are certain materials that have a very high “go-through-able-ness” for magnetic lines of force. We say these materials have a high permeability and the most common material of this type is iron.

Many alloys of iron, cobalt and nickel have been produced that have extremely high permeabilities, but they are generally high in cost and have other undesirable characteristics. Certain steels that have a relatively high silicon (one of the natural elements) content seem to have very desirable characteristics and this makes these steels very suitable as "flux guides." But let's junk this high powered, although descriptive term "flux guide," and simply refer to it by its common name—the core.

A transformer then consists of two windings, primary and secondary, and a magnetic core linking the two. In the case of transformers operating at power frequencies such as welding transformers, the magnetic material is usually silicon steel. The two basic raw materials going into the construction of a transformer are copper and silicon steel.

Let's examine the core a little more closely. First, we can consider the shape of the cores. We must remember that the purpose of the core is to act as a "flux guide" and then we can realize why various shapes are used.

In the following diagrams, we show several transformer types.

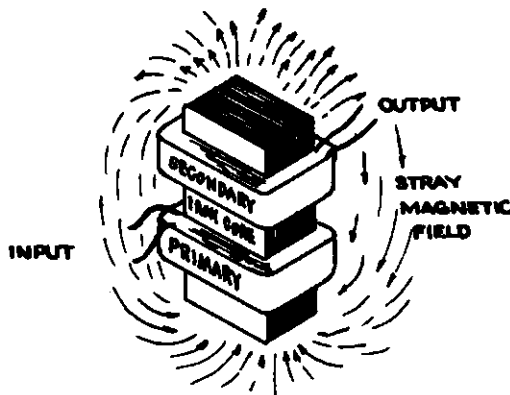

Fig. 10, above. Transformer construction showing one legged open core. This is not a very practical type of design for power transformers.

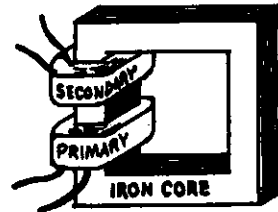

Fig. 11, above. Closed "U" core. Both primary and secondary are on one leg.

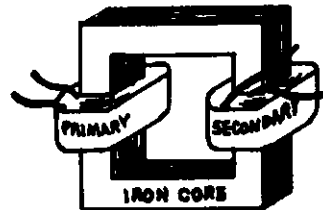

Fig. 12, right. Same core as in figure 11 but primary and secondary on opposite core legs.

Figure 10 shows the one legged open core. This is a relatively poor design and the stray flux (as shown by the dashed arrows), spreads over the landscape.

Figures 11 and 12 show the two legged closed cores. This type of design is much more efficient and many transformers are built this way. Note that the windings may be on the same leg as in (11) or on separate legs as in (12). The most efficient type of construction is shown in figure 13 which is the three legged closed core construction.

In figure 14, we show a sketch of the design used on all MILLER transformer type welders. You will note that this design allows a threaded rod to be placed between the two cores and provides a convenient method of moving the primary closer to, or farther away from, the secondary, which remains stationary in all MILLER welders. More later about the functioning of this "current control" method.

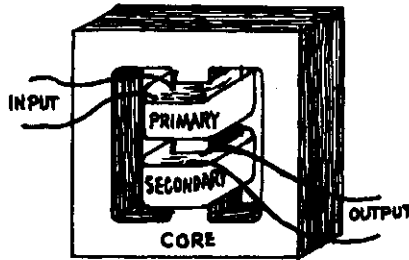
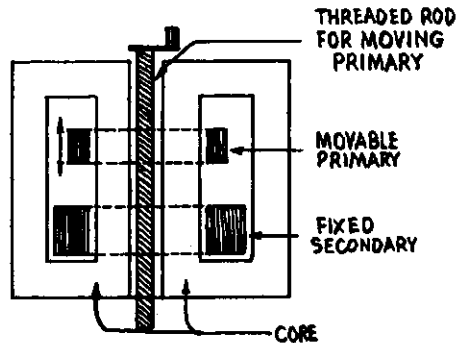

Fig. 13, left. Most efficient basic transformer design. Three legged core, often referred to as a "closed E" lamination.

Fig. 14, right. Basic design of MILLER transformer type movable primary coil arc welder.



Let's continue with the discussion of the magnetic core. You may have wondered why, in all cases, the core is laminated. Why not use a solid core of silicon steel—it certainly would be no trick to cast such a core. To get the answer to this, we must go back to the fundamental idea of the transformer. Unfortunately (for our purpose), silicon steel or any other ferro-magnetic material, is a metal and therefore a pretty good electrical conductor. Let's see then, what would happen if we used a solid core. Figure 15 is a cross-section of a transformer leg on which the primary is wound. Imagine for a moment that the core is not there. If you could now place a coil of wire inside the primary, you could readily see that a current would be induced in this loop.

Naturally, we are assuming that the primary is always energized with alternating current and thus produces a continuously changing magnetic field, the basic requirement of electro magnetic induction.

We have, however, actually a block of silicon steel as a core. The steel is a pretty fair electrical conductor so we do have a conducting path right where we had imagined the loop. There is nothing therefore, to prevent a current from being induced IN THE CORE and circulate along the path shown in the diagram.

Any time that you have current flowing through a conductor, you have heating of the material. You can readily see that if we wanted to HEAT the core, this might be a pretty good method of doing it. (Incidentally, this is the basic idea of induction heating used so extensively in industry.) Obviously, however, any heat being produced in the transformer is going to detract from the efficiency of the transformer as such. Some way should then be found to eliminate, or at least reduce to a minimum, this heating of the core.

Fig. 15. Solid core showing eddy current path which contributes to transformer losses.

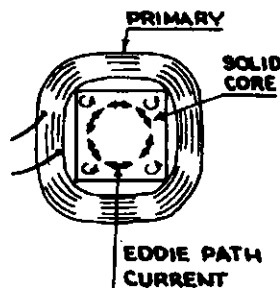

If we could break up the iron core into INSULATED segments such as insulated laminations or wires, this ought to do the job. Iron wires have been used, but by far the best results have been achieved with laminations. Please note that these laminations must be insulated from each other.

Actually, no great pains need be taken to insure this since iron oxide (rust) is a very good insulator for this purpose. Certain enamels and coatings can be, and usually are, placed on the sheets to serve as insulation. It also is very convenient to stamp or shear these laminations and then stack them in such a manner to get the desired shape and size of core.

Now, you can see why the fellow got into trouble who, when rebuilding an old transformer, thought that he should take sandpaper and clean off the rust from the laminations and make them nice and bright and shiny before restacking. He had a nice looking transformer, but it acted more like an electric stove than a transformer.

Now another important question usually comes up and that is why is it that a transformer primary can be connected to a source of alternating current, but as long as no load is connected to the secondary, little or no energy is drawn by the primary? Before we go into detail in answering this question, let's perform a little experiment that may seem to be unrelated at first, but actually holds the key to the answer to our question.

For a moment, let's consider our simple coil as shown in figure 16. we will make the hook-up as shown in the diagram, using a battery (direct current, of course—remember?) and a switch and light. The light is of the type, such as a neon bulb, that will light instantly and not require appreciable time for a filament to get hot. We choose a battery voltage that is too low to normally light the bulb. We close switch (A). Current flows through the coil. The bulb does not light up

because the battery voltage is below the bulb threshold. Now we open switch (A). Lo and behold, the bulb flashes. Somehow or other then, we must have gotten a voltage HIGHER than the battery voltage.

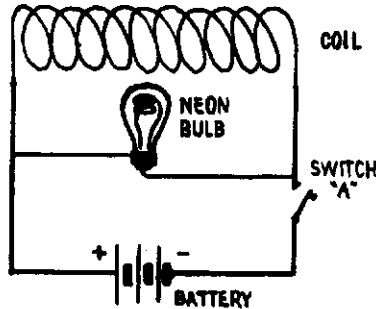

Fig. 16. Simple experimental set-up to demonstrate self-induction in a solenoid. The battery voltage is below that required to light the neon bulb.

Let's see what really happened. While the switch was closed, we had a STEADY magnetic field produced by the coil. When the circuit was opened, the magnetic field collapsed and, of course, we then had a changing magnetic field. This changing magnetic field then induced a voltage in the very same coil that had been used to produce the field in the first place. The voltage developed depends entirely on the rate at which the field lines are cut (speed with which the field collapses) and the number of turns on the coil. Notice that it has absolutely nothing to do with the voltage of the battery. This is the important point to keep in mind, *only the time rate of change of the magnetic field* affects the voltage induced per turn.

A careful analysis will also show that the induced voltage is such that it will oppose the voltage that caused the field to change. This, incidentally, is known as Lenz's Law, one of the basic laws of electricity.

Let's think about this just a bit and apply the law to the circuit under consideration, Figure 16.

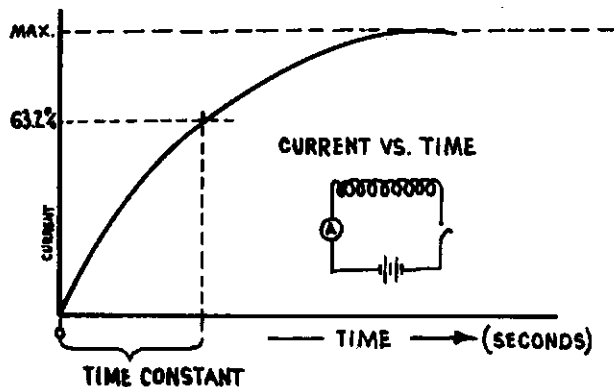

Fig. 17. Graph showing current build up as a function of time in an inductive circuit.

When we close switch "A," a current starts flowing through the coil. At one instant (just before the switch is closed) there is no magnetic field and the next instant we have a maximum magnetic field. Obviously, during the interval we have a "changing magnetic field" and a voltage which OPPOSES the battery voltage is induced in the coil. In other words then, work must be done and energy expended to force the current through the coil and set up the magnetic field. The result is that it takes appreciable time to build up the current through the coil. The graph shown in figure 17, gives an idea of the time involved. (Incidentally, the time required for the current to reach 63.2% of its maximum value is called the "Time Constant" of the circuit—in seconds.)

Looking back several chapters, we recall the statement that a magnetic field represents energy (the ability to do work) and since we never get something for nothing, it is only logical that work must be done in order to establish the field.

Now, let's see what would happen when the circuit is opened and the field is allowed to collapse. As we pointed out before, a voltage will be induced in the coil and its direction will be such as to tend to keep the current going and not allow the field to collapse. Since the coil circuit is now only complete through the neon bulb (since the switch is open), the current will flow through the bulb and cause it to light.

Now, we can make a very useful, general statement. We can say that when the current is started, energy is used to set up the magnetic field and this *energy is stored in the field*. When the magnetic field collapses, the energy is returned to the circuit.

As in previous cases, let's see what would happen if we applied alternating current to the same coil. The condition just discussed above, would exist all of the time. Energy would be put into the magnetic circuit when the current is increasing and would be returned to the circuit when the current is decreasing. If none of the energy that is stored in the magnetic field is used (to produce mechanical motion or converted into heat or radiated into space) then the amount returned to the circuit will equal the amount drawn from the circuit previously. The net result, therefore is that *no energy is used*.

Does this mean, then, that no current flows in the primary circuit? Not at all, but the actual condition is that the current is not in step with the voltage. We can show mathematically that actually in a coil having no resistance (theoretically) and thus exhibiting no heat losses, the current lags 90° or 1/4 of a cycle behind the voltage.

Actually, then, a transformer primary can be connected to the line and draws no energy from the line—even though a current may be flowing in the primary circuit.

The current drawn by a transformer primary under idling conditions is generally referred to as the "exiting current" and generally speaking, the exiting power that is drawn by the transformer under these conditions (just enough to supply the heat losses), gives a good indication of the efficiency of the device. Highly efficient transformers have very low exiting currents.

Now, we can talk about "*power factor*" in electrical devices, and

in light of the points brought out in this chapter, let's become acquainted with a few general terms.

First of all, consider the characteristics of a coil. The number of turns, the shape of the coil and the magnetic characteristics of the core material, determine the "self inductance" of the coil. The unit for self inductance is the "henry." The definition of the henry is as follows: "If, due to a current change of one ampere per second, there is induced in the coil a voltage of one volt, then the coil is said to have an inductance of one henry."

We also can see from previous discussions that the result of inductance in an A.C. circuit is to "choke off" the A.C. current flowing in the circuit. This "holding-back-effect" is called the inductive reactance and it is measured in ohms. This means, of course, that when we are trying to apply Ohm's Law to A.C. circuits, we must consider the resistance of the circuit AND the inductive reactance. Together these two quantities are known as the "impedance" and this quantity is also measured in ohms and is usually represented by the letter Z in electrical equations.

We now can make use of "A.C. Ohm's Law" by substituting the letter Z for R in standard equation that we discussed in Chapter III. The A.C. Ohm's Law then becomes:

$$I = \frac{E}{Z}$$

Where: I = current (amperes)

E = voltage

Z = impedance (ohms)

If we now look at Z a bit more closely, we can see that it will be dependent upon the following factors:

1. The resistance of the wire (R).
2. The inductance of the coil (L), which, in turn, depends upon the number of turns, the shape of the coil and the core material.
3. The frequency (f) of the supply voltage since this determines the rate at which the current will change in the circuit.

Mathematically we can derive the following equation which is the correct expression for impedance:

$$Z = \sqrt{R^2 + (2\pi fL)^2}$$

Where: R = resistance (ohms)

π = 3.1416

f = Frequency (cycles/second)

L = inductance (henries)

Z = impedance (ohms)

We now have practically all of the information and tools to handle simple A.C. problems. At least, we can apply Ohm's Law to A.C. circuits now and can calculate the current, voltage or impedance in a circuit if two of the three quantities are known.

Before we go on, let's work out a sample problem and see how these powerful mathematical tools can be used.

EXAMPLE: A coil having an inductance of .05 henries and a resistance of 7 ohms is connected to a 120 volt, 60 cycle A.C. line. What current will flow through the coil?

Given: $L = 0.05$ henries

$R = 7$ ohms

$E = 120$ volts

$f = \text{c.p.s.}$

Required:

I (in amperes)

From A.C. Ohm's Law

$$I = \frac{E}{Z}$$

We have E given, but must determine Z , therefore:

$$\begin{aligned} Z &= \sqrt{R^2 + (2\pi fL)^2} \\ &= \sqrt{(7)^2 + (2 \times 3.1416 \times 60 \times .05)^2} \\ &= \sqrt{(7 \times 7) + (18.84 \times 18.84)} \\ &= \sqrt{49 + 355} \\ &= \sqrt{404} \\ Z &= 20.1 \text{ ohms} \end{aligned}$$

Now substituting the value of Z in the equation above we get

$$I = \frac{120}{20.1} = 6$$

$\therefore I = 6$ Amperes (Ans.)

I realize that if you're not too good at figures, (mathematical, that is!) this may appear pretty rough—but a little digging and your high school algebra will come back. Of course, you can skip the math—but then a lot of things must be taken for granted.

We have now laid the foundation for the discussion of power factor which will start in earnest in the next chapter.

CHAPTER IX

LEADING UP TO SOMETHING

Any discussion at all about alternating current will soon bring to light the term "Power Factor" and a lot of mumbo jumbo with which the electrical engineer is perfectly familiar, but which usually leaves the average person pretty much at sea. Like many other things, an understanding of power factor is not difficult, if the subject is approached logically.

In the preceding chapter, we mentioned the fact that in an inductive circuit the current is not in step with the voltage. It was pointed out that it could be shown mathematically that in a circuit consisting only of inductance (having zero resistance), the current is lagging the voltage by 90° or $1/4$ of a cycle. Now, whether we like it or not, we must dig just a bit into mathematics in order to appreciate the numerical significance of power factor.

Here then, is the plan. Let's plot the current and voltage of a purely inductive circuit on the same graph. In figure 18, we use the solid line labeled "I" as the current trace and represent the voltage by the dotted line labeled "E."

Since the current is lagging behind the voltage $1/4$ of a cycle, we can say that the voltage leads the current. Now, when the current is zero at the start, the voltage has already gone through $1/4$ of a cycle and is at positive maximum. When the current has reached its positive maximum, the voltage has already reached zero, and so on.

In order to identify the various time points that we are going to discuss, let's identify them as a, b, c . . . k which represents one complete current cycle.

So that we might have real numbers to work with in our discussion, let's say that the maximum voltage is 10 volts and the maximum current is 6 amperes.

Fig. 18. Graph showing instantaneous voltage and current in a purely inductive circuit connected to an A.C. voltage source. The points identified by letters correspond to the instants as shown on the chart in figure 19.

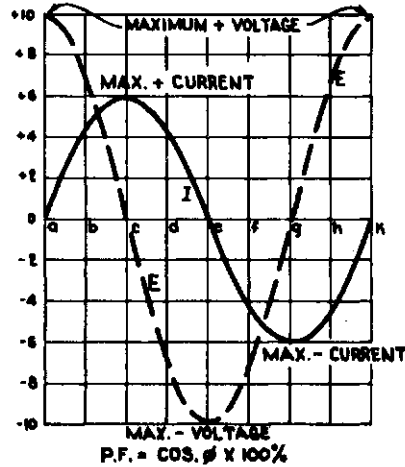

From previous discussions, you will remember that the voltage times current gives us the power in watts. We can now take the instantaneous voltage and current off our graph at the various positions and calculate the instantaneous power. In the chart below, we list in the first column the time position as a b, c, etc. The second column is the voltage at that instant and the third column is the current at the same time. By multiplying the figures in columns two and three, we get the instantaneous power and list this in the fourth column.

Pos.	$E_{inst.}$ (Volts)	$I_{inst.}$ (Amps)	$W_{inst.}$ (Watts)
a	+10.0	0	0
b	+7.07	+4.24	+30
c	0	+6	0
d	-7.07	+4.24	-30
e	-10	0	0
f	-7.07	-4.24	+30
g	0	-6.0	0
h	+7.07	-4.24	-30
k	+10.0	0	0

We must observe the basic algebraic rule of multiplication. When numbers of like sign (both positive or both negative) are multiplied, the product is positive, but when the two numbers have unlike sign (one positive and the other negative), then the product is a negative quantity.

Fig. 19. Chart showing instantaneous voltage, current, and power in the inductive circuit using values shown in figure 18.

Another point to remember is (it can be shown mathematically), that when two changing quantities that can be represented by a sine wave (as our voltage and current) are multiplied, the product is also a sine wave. If we now plot the instantaneous power on a graph similar to the one in figure 18, we get something like this:

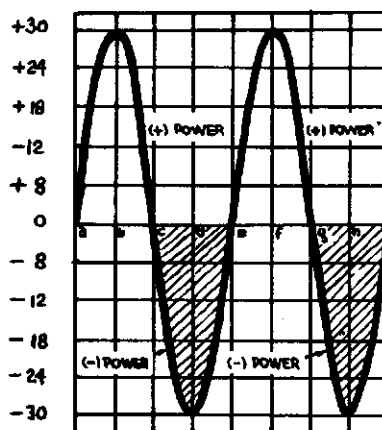

Fig. 20. Graph showing instantaneous power in an inductive circuit. Data is the same as shown in figure 19.

Note that the time position marks are the same as in our first graph. The power curve has two positive and two negative peaks and completes two cycles during the same interval that the current goes through only one cycle.

This curve is very interesting and bears closer study. We can readily understand the positive loops of the power curve—this represents energy drawn from the line—but then the negative loops (shaded areas) must represent just the opposite, or energy returned to the line. This bears out our statement that we made in the last chapter when we said that in a magnetic circuit, energy is *stored* in the field and *returned* to the circuit.

If the positive and negative loops are exactly equal, the net result is that no energy is used up because the average power is zero.

So far, we have been talking about a pure inductance, something that exists only in theory, since an inductor is composed of wires—and wires have resistance. Now, let's see what happens when we analyze a resistive circuit. Using the same plotting method and values as before, we plot the voltage and current on our graph in figure 21.

In this case, of course, the voltage and current are in step (in phase) and the maximum positive voltage occurs at point c, where the maximum positive current point is also located.

Fig. 21. Graph of instantaneous voltage and current in a purely resistive circuit. Note that maximum and minimum voltage and current occur at the same instant.

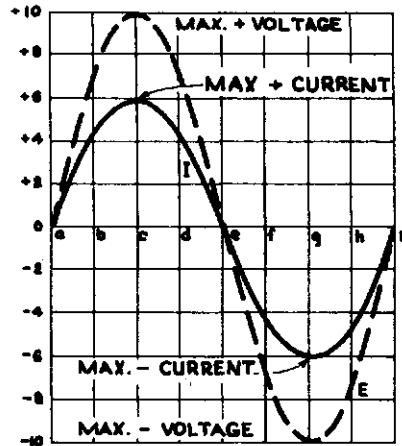

Now if we take the instantaneous values of voltage and current as plotted on the graph in figure 21 and calculate the instantaneous power (volts times amperes) at each point we can tabulate the values as shown below.

Pos.	$E_{inst.}$ (Volts)	$I_{inst.}$ (Amps)	$W_{inst.}$ (Watts)
a	0	0	0
b	+7.07	+4.24	+30
c	+10.0	+6.0	+60
d	+7.07	+4.24	+30
e	0	0	0
f	-7.07	-4.24	+30
g	-10.0	-6.0	+60
h	-7.07	-4.24	+30
k	0	0	0

Notice that the product, voltage times current, is always positive because we are always multiplying terms having the same sign.

Fig. 22. Chart showing instantaneous voltage, current, and power as a purely resistive circuit using values plotted in figure 21.

If we now take the data tabulated in the $W_{inst.}$ column in the chart above and plot these figures on a graph whose time axis (horizontal) is on the same scale as before, we will get a curve as shown in figure 23.

When we compare this to the power curve as shown in figure 20, we note that the shaded loops (negative power) have now entirely disappeared and that the power drawn from the line now is at a maximum.

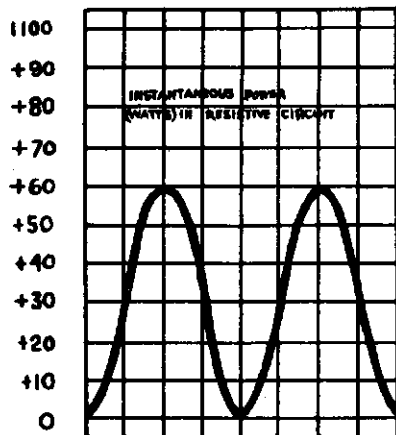

Fig. 23. Graph showing instantaneous power plotted from chart in figure 22. In comparing this to figure 20 note that a different vertical scale is used.

We can now conclude that the average power drawn from the A.C. line by any device would depend on how closely the current and voltage are in step with each other. It is easy to see now that multiplying volts times amperes does not give us watts in an A.C. circuit if any inductance is present. This is the reason why technical people speak of KVA ratings (kilo volt-ampere) rather than KW (kilowatts) when they are interested in volt times amperes.

Now, let's speculate as to what would happen in between the two extreme cases just discussed. In the case of the pure inductive circuit, the current lagged $1/4$ of a cycle or 90° behind the voltage. In the resistive circuit, there was no lag and the angle of lag was therefore 0° . This angular difference between the current and voltage is called the "phase angle" and may have any value from 0° to 90° , and is usually designated by the Greek letter ϕ .

Let's again refer to figure 20. As we indicated before, here the phase angle is 90° and the negative power loops are equal to the positive loops. In figure 23, the negative loops have disappeared and the positive loops have become twice as large and this is characteristic of 0° phase angle. Obviously now, for phase angles between these two extremes, the negative loops will get smaller and smaller as we go from 90° to 0° phase angle.

Actual measurements will show the following relationship between the product of volts times amperes and watts at different phase angles. Again for illustrative purposes, we can use our value of 10 volts and 6 amperes and we tabulate the results in figure 24.

The last column headed % indicates what percentage of the product of volts times amperes yields watts in A.C. circuits having various degrees of phase lag.

This percentage term is called the "power factor." It can be arrived at experimentally by measuring the various values for different phase angle conditions, but we can also derive it mathematically as "the cosine of the phase angle."

Phase Angle	VxA	Watts	%
0°	60	60.0	100
10°	60	59.0	98.5
20°	60	56.4	94.0
30°	60	52.0	86.6
40°	60	45.8	76.6
45°	60	42.4	70.7
50°	60	38.5	64.3
60°	60	30.0	50.0
70°	60	20.5	34.2
80°	60	10.4	17.4
90°	60	0.0	0

Fig. 24. Chart showing relationship between the product of volts times amperes, and watts at different angles of current lag or lead.

For example, suppose we have an A.C. transformer type welder that draws 70 amperes from the 220 volt line and the phase angle is 30° (the current lags 30° behind the voltage), then to find the power that the welder draws from the line, we take:

$$70 \text{ A} \times 220 \text{ V} = 15400 \text{ VA or } 15.4 \text{ KVA}$$

$$15.4 \text{ KVA} \times 86.6\% = 13.35 \text{ KW}$$

Summarizing now, we can see that in an A.C. circuit, we cannot calculate the power in watts by multiplying volts times amperes, but must take a certain percentage (power factor) of this product in order to get watts.

The power companies do not like low power factor loads—and you can see why. Suppose you have a device that draws 100 amperes from the line, and its power factor is only 10%, let's say. At 220 volts, your demand on the power company would be 22 KVA, but actually, you would only use and have to pay for, 2.2 KW.

Power companies therefore, have a rate system set up that penalizes low power factor loads, and this brings up the next question—what can we do about low power factor—a point that will be discussed in detail in the next chapter entitled "Cosine Phase Angle."

CHAPTER X

COSINE PHASE ANGLE

We have pretty well established the point that any alternating current circuit containing electromagnetic devices, i.e., any inductive circuit, causes the current to lag behind the voltage and results in a power factor less than one or 100%.

In the last chapter we tried to explain why this occurred, and also pointed out that this was usually an undesirable condition. Now the question comes up of what to do about it.

We started this series with a discussion of the various electrostatic phenomena. We showed that a positive charge is simply a scarcity of electrons at a certain location and that, conversely, a negative charge is an over-supply of these same negative particles.

Let's perform another simple experiment in electrostatics and see what conclusions can be drawn from the results.

Suppose we take two metal plates as shown in figure 25. Note that the plates are not in contact but are separated by an insulator (air in this case). Both plates are electrically neutral which simply means that neither over-supply nor deficiency of electrons exists on either plate.

Now let's connect an "electron" pump (generator), any device that can cause electrons to move, between the two plates as shown with dotted lines in figure 25.

We can readily see that as this generator starts to "pump" electrons from plate A, a positive charge starts to build up on this plate. The electrons are not used up but are simply moved over to plate B causing a corresponding negative charge to build up on this plate.

As the scarcity of electrons gets greater on plate A, it's going to be harder for the pump to remove more electrons. Remember, unlike charges attract.

Fig. 25. A simple idealized capacitive circuit. The "electron pump" may be a battery or a generator.

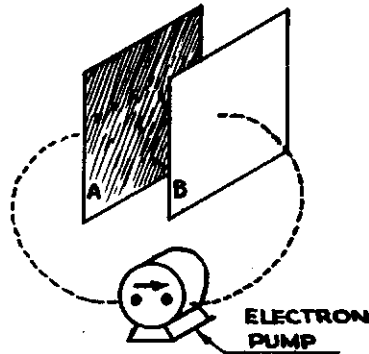

As plate B becomes over-populated with electrons, it also becomes more difficult for the electron pump to add more electrons, since like charges repel and the negative charge on plate B opposes further electron arrivals. Pretty soon the pump is unable to force any more electrons to plate B, and the forced electron migration from A to B stops.

Before we leave this simple experiment, let's look at the electron flow. At first, there was little opposition to the electron motion. The pump had no trouble and there was a great rush of electrons. Then the back pressure started to build up and things got tougher. The electron flow became less and less and finally stopped.

Another way of describing the process is to say that the electron flow (current) was maximum when the back pressure (voltage) was zero, and that the current became zero when the voltage reached its maximum value. Keep this idea firmly in mind.

Let's speculate a little more. Just suppose that at the time that the electron pump had stopped being effective in moving electrons to plate B, we had stopped operating it. The pressure that had been built up on plate B would force electrons back through the pump and cause it to turn in the opposite direction until all of the displaced electrons had returned to plate A and neutrality had been re-established. At this instant we continue to turn the pump in the same direction and now we create a negative charge on plate A. We go through the same process as before.

Here we are getting a result very similar to that encountered when we created magnetic fields in the case of the inductive circuit. We stored energy in the magnetic field during a portion of the cycle and had it returned to the line during the next interval.

Here, however, we are not dealing with magnetic fields but with *electrostatic fields*. The device that we use to store energy is not an inductor but a capacitor. The term "condenser" has been very popular in the past but is being replaced by the more suitable name "capacitor."

Suppose that we now set up the circuit as shown in figure 26. We have an alternating current generator connected to a capacitor with a current detecting device in the circuit as indicated.

If the electrical "capacity" of the capacitor is great enough (to supply plenty of electrons during a cycle of the electron pump) as far

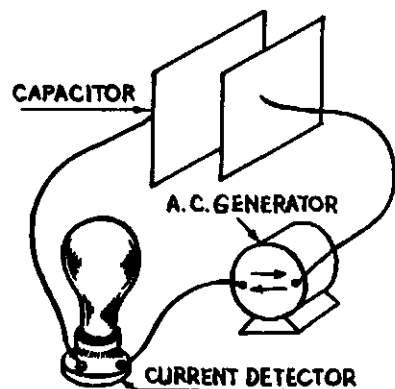
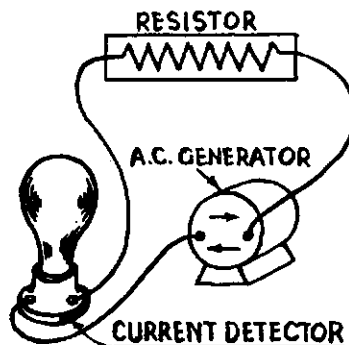

Fig. 26. A simple capacitive circuit connected to an alternating current generator.

as the current detector is concerned, the circuit of figure 26 might just as well be like that of figure 27—*except* that the current is not in step with the voltage.

Fig. 27. The capacitor of the circuit shown in figure 26 has been replaced by a resistor.



A little thought will show that the current should be ahead of, or be leading, the voltage.

This is true, and it can be shown mathematically that in a capacitive circuit, the current is leading the voltage by $1/4$ cycle or 90° .

Now just think of the various possibilities that might exist when we combine the inductive and the capacitive circuit into one. The first obvious application is in power factor correction.

Remember that the current in an inductive circuit *lags* behind the voltage, depending upon the amount of energy that is removed from the inductive circuit. We can show that in the case of a situation where current is lagging some intermediate value (between 0° and 90°) the current can be thought of as consisting of two components. One part, representing the useful power, is called the resistive component and is in step with the voltage. The other part, called the reactive or wattless component, lags behind the voltage a full 90° .

Now as we have seen, the current in a capacitive circuit is leading the voltage by 90° .

Well then, why not connect a capacitor to the same line as the inductive device and have the leading current of the capacitor CANCEL out the lagging current of the wattless component? That is exactly what is done.

We can choose the size of the capacitor so that its current under given conditions just equals the wattless component of the inductive circuit and the power factor is increased to 100%.

In the case of some such device as a transformer type arc welder where the current setting of the device will vary the current that the transformer draws from the line, a variable capacitor would have to be used to provide 100% power factor at all settings. Indeed, some large power factor correction devices, installed in large industrial plants, do change capacity automatically to compensate for varying loads.

In actual practice, arc welders of the transformer type are equipped with capacitors of sufficient size to provide 100% power factor at, or near, the rated output. Under idling conditions these devices would present a leading power factor to the line and thus help to compensate for other inductive devices in the same plant.

Any inductive device then can be power factor corrected so that it will present the same type of load as a purely resistive device by proper application of capacitors.

Note that in the various specifications for MILLER transformer type welders, the primary current at rated output is always less in the power factor corrected model than in those not power factor corrected. This does not mean that the non-power-factor-corrected model uses more electricity since the input in KW is exactly the same. It does mean that the KVA input is reduced and in cases where the power service is limited, a power factor corrected device is the only type that can be used.

Capacitors used for power factor correction come in many sizes and shapes and the story on the structure of a capacitor must await some later date.

CHAPTER XI

THEORY AND PRACTICE

In the design and application of electrical devices there is always the difficulty of matching the theoretical approach with the practical. This dilemma can be partially resolved by the use of an equivalent circuit.

As a point of illustration, suppose we consider the method in the design of a welding transformer.

To simplify matters, we can begin our analysis by an examination of a simple cell or battery and investigate the matter of energy transfer from source to load.

There are many types of batteries but they have the following points in common:

- No. 1. The voltage or potential of the cell depends upon the type of chemical action involved and is not related to the physical size of the cell. The pen light cell and #6 dry cell are of identical chemical make-up and therefore the voltages are identical, although the #6 dry cell is many times the larger.
- No. 2. All cells have "internal resistance." We can make an analogous statement by saying that "there is no such thing as a frictionless pump."
This, as we shall see, limits the power output of the cell.
- No. 3. The total energy output of a cell generally depends upon the size of the cell or more basically, the amount of active chemicals available.

We are all familiar with the fact that the voltage of a cell varies with different loads. This is a result of the internal cell resistance and is brought about in this manner.

Suppose the simple circuit shown in figure 28, consisting of a battery, a resistance and an ammeter is set-up.

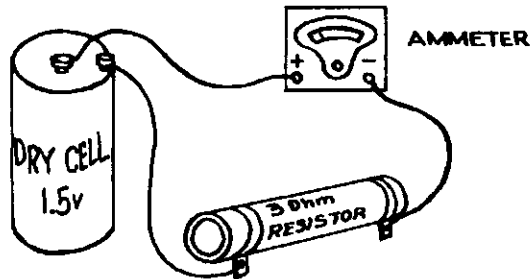

Fig. 28. A simple circuit consisting of a source of potential (dry cell), a resistance, and an ammeter to measure the current flow in the circuit.

We assume, since the voltage of the cell is 1.5 volts, that the current in the circuit will be given by Ohm's Law:

$$I = \frac{E}{R} = \frac{1.5}{3} = 0.5 \text{ Amps.}$$

Upon close examination of the ammeter, we find that the actual indicated current is slightly less than that, and our "apparent error" increases for higher currents.

Now we make use of the equivalent circuit. Since we pointed out that all cells have internal resistance, this must be taken into consideration. So we simplify our circuit by representing the cell as a perfect generator having no internal resistance, in series with the internal resistance as shown in figure 29.

The internal resistance must be shown in series, because all of the electrons that are forced through an external circuit must go through this resistance R_i .

It should be pointed out that this is purely a theoretical device and that in actual practice, the two terms E and R cannot be separated. In other words, it is impossible in practice to get inside the dotted line fence of figure 29.

Now our circuit of figure 28 can be represented schematically like this in figure 30:

The actual terminals of the battery or cell are labeled (a) and (b) in the diagram. We can now see that the voltage appearing at terminals (a) and (b) under load would be E minus the drop in the internal resistance R_i .

Suppose that the current in the circuit is 0.33 amperes. Then the internal drop, assuming R_i to be 1.5 ohms, would be $(I \times R_i)$ 0.5 volts. Subtracting this from the "open circuit" voltage of 1.5 volts, leaves

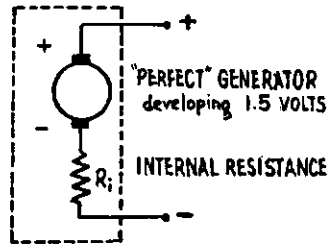
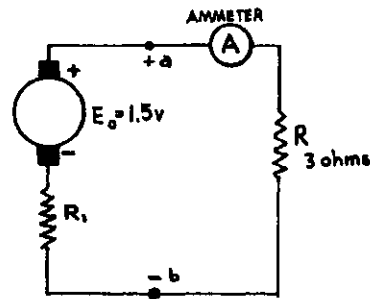

Fig. 29, left. The "equivalent circuit" of a simple dry cell.

Fig. 30, right. Equivalent schematic diagram of the circuit shown in figure 28.



just 1.0 volt at the battery terminals. Now if we apply Ohm's Law to the external circuit, we find that our meter reads correctly and our "apparent error" vanishes.

A simpler way to analyze the problem, and the method that is usually used, is to consider the circuit as a whole and lump the internal resistance with the external load.

Using this method, we find that the total resistance in the circuit would be 3 ohms plus 1.5 ohms, or a total of 4.5 ohms. Using Ohm's Law to find the current, we come up with:

$$I = \frac{E}{R} = \frac{1.5}{4.5} = 0.33 \text{ Amps.}$$

It should be quite apparent now that at any time the cell or generator is delivering current into an external circuit, that current must also be flowing through the internal resistance and as a result, internal heating should take place.

It is impossible to draw power from any source without causing that source to heat from internal losses. These internal losses of course, reduce the overall efficiency of the device so it becomes obvious that they, the losses, should be kept as low as possible.

We might now investigate the problem of getting the maximum power transfer from generator to load.

Referring again to figure 30, we see that the total resistance is equal to the sum of the load resistance R and the internal resistance R_i . For conditions of maximum current, we should make this sum as small as possible. It is possible to vary the external load resistance, but generally we have no control over R_i , this being dependent upon the type and size of cell.

To get the absolute maximum of current to flow, we could simply make R zero but then there would be no power in the external circuit and all of the energy would be dissipated inside the battery (which would soon ruin the cell).

The power in the external or load resistor is equal to I^2R and the power inside the cell is I^2R_i . It should then be noted that up to a certain point, it is advantageous to decrease the external resistance so that the current will increase, but there comes a point of diminishing returns where an increase in current brought about by reducing the load resistance, will actually reduce the power put into the load.

Either by plotting the power output into a load as a function of load resistance graphically, or by the use of calculus, it can easily be shown that:

"Maximum power transfer takes place from a generator into a load if the load impedance is equal to the source impedance."

This is an extremely important electrical theorem and has universal application.

Specifically now, let's consider the standard transformer type arc welder and see how the above principles can be applied.

The equivalent circuit of the arc welder can be represented by the schematic diagram in figure 31.

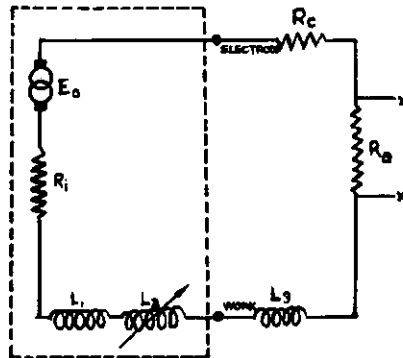

Fig. 31. A simplified "equivalent circuit" of a standard A.C. transformer type arc welder.

Consider the welding transformer as being equivalent to a perfect alternating current generator, putting out voltage E_0 (the open circuit voltage of the welder), in series with a resistance R_i made up of the D.C. resistance of the winding of the secondary, and the inductances L_1 and L_2 . L_1 represents the minimum inductance (both direct and reflected) of the secondary circuit, and L_2 is the variable portion of the inductance that is used for current control. In some machines, L_2 is actually outside of the transformer, but in the moving primary coil type of welder, it is inherent in the machine.

Everything within the dotted area is then confined to the welder itself and the external circuit is connected to the terminals marked "electrode" and "work."

The external circuit is considered to consist of R_e , the resistance of the welding cable and ground lead, L_3 , the inductance due to coiling of the leads and iron enclosed within the welding loop, and lastly, R_a , the resistance of the arc itself.

The whole idea of the welding process is to get the maximum energy into R_a with the best efficiency.

R_e and R_i will rob energy from the system, so it behooves us to keep these values as low as possible under the circumstances. R_e is directly proportional to the length of the welding leads and inversely proportional to the cross-sectional area of the cable used. The best rule is to keep the welding leads as short as possible at all times and follow the manufacturer's recommendations for minimum cable size.

The value of R_i is determined by the designer of the machine and involves the rating of the machine. From the user standpoint, it is generally more economical to operate a welding transformer below its rating than to operate one above its rating. This is obvious when we realize that the higher the rating of the transformer, the lower the internal resistance. With certain exceptions then, it is good practice to let a larger machine "loaf" than to make the smaller machine "puff" to get the job done.

The inductances in the circuit will serve to limit the current but will not detract from the efficiency. L_3 is generally inconsequential, except when some people coil up the excess welding cable for appearance purposes. This also might become a factor if a great deal of iron is included in the welding loop such as is frequently the case where A.C. welding is done on construction jobs.

In D.C. welding, L_3 has no effect on the welding current.

L_1 in connection with R_i will limit the current available at the welding terminals under maximum load conditions, while L_2 serves to control the current in the usable welding current range.

The equivalent circuit of figure 31 makes the analysis of the welding circuit much simpler and allows the designer to apply the mathematical approach.

There is some over-simplification in this discussion since R_a is not a definite fixed resistance. This value is determined by dividing the voltage appearing across the arc by the current flowing through the circuit (Ohm's Law), but the important point here is that the voltage across the arc depends upon several factors, such as the length of the arc, the material in the arc and to some extent, temperature. The designer must therefore strike a compromise and assume a certain arc voltage at the rated current.

At the rated current, the power (rate of energy flow) dissipated in R_i must be low enough so that under the given "duty cycle" the temperature of the insulation and other parts must not go beyond safe allowable limits.

Now we are in a position to discuss duty cycle and power rating much more intelligently.

CHAPTER XII

JOULES AND WATTS

Now that we have gotten a pretty fair idea of how a theoretical equivalent circuit can be used to analyze a real electrical circuit, let's see how useful it can be in studying the welding transformer.

The rating of a welding transformer usually is based on three characteristics: The open circuit voltage, the rated current, and the duty cycle. In order to get a clear picture of any welding transformer, all three parameters must be considered. In other words, if we look at a welder only from the standpoint of rated welding current, we discover that there is a vast difference between some machines that might be carrying the same current rating.

Neither is the O.C.V. nor the duty cycle alone a good indication of what the welder will do. By making use of our equivalent circuit, we can show that all three factors are very closely related and only by considering all three can we arrive at a figure of merit of a welding transformer.

Suppose we use the simplified equivalent circuit of a standard welding transformer as shown in figure 31 and start by examining each portion shown within the dotted area.

Consider first of all E_0 . This is the open circuit voltage and is symbolized by the output voltage of a "perfect" A.C. generator. Just what determines the value of E_0 ?

There are two things, and only two involved, namely, the turns ratio and the line voltage.

Now if we refer back to the chapter of Basic Electricity in which the transformer was discussed, we find that a transformer can transform voltage to a higher or lower value and thus be a step-up or a step-down transformer. Actually, the ratio of secondary to primary

turns determines the voltage ratio. A transformer having more turns of wire in the secondary than in the primary, is a step-up transformer, while one having fewer turns in a secondary than in the primary is a step-down type. The secondary to primary voltage ratio is identical to the turns ratio.

Incidentally, we might also point out in passing that frequently it is desired that one A.C. circuit be isolated from another but we do not want any voltage change. In that case, a transformer having a 1 to 1 turns ratio is used. This transformer, which neither steps up the voltage or lowers it, is called an isolation transformer.

But back to our welding transformer.

Most industrial A.C. power supply lines are 220 or 440 or even 550 volt lines. It is quite obvious that voltages of this magnitude are much too high from a safety standpoint to be utilized directly for welding applications. All welding transformers are, for that reason, step-down devices. Experience has shown that O.C. voltages between 55 and 90 volts are suitable for general metallic arc welding. In choosing a certain open circuit voltage the designer must be governed by several factors of which operator safety, arc stability and flexibility are a few of the more important items.

Let's for the sake of illustration, say that 80 volts is the value of O.C.V. desired. The designer then determines his turns ratio from the voltage ratio. He must assume a line voltage and let's say that 240 volts is his design value. (Line voltages vary in different locations and there is a general trend upward so that many "220 volt lines" are actually higher than 220 volts.) His turns ratio then must be $240 \div 80$ or 3. That means that he must have three times as many turns on the primary as on the secondary.

By taking several factors into consideration that we won't discuss at this time, the designer decides that he will use (let us say) 90 turns of wire on the primary—he knows then that his secondary must consist of 30 turns.

Now let's see what the 30 turn secondary will do. The wire, of course, has resistance. That means we can represent this by R_i in our equivalent circuit. The larger the size of wire, the less will be the resistance—but that also means higher cost. We must therefore literally "buy" low resistance and the designer uses the largest wire size that he can "afford."

Perhaps we should again review why the lowest possible resistance value of R_i is desirable. While the transformer is delivering current to an external load (while welding), a certain amount of heat energy is released in the secondary winding. The lost power is given by:

$$\text{Power (in watts)} = I^2 R_i \quad (1)$$

where: I is the current in amperes

R_i is the resistance in ohms

This power is, of course, lost and merely serves to heat up the transformer and surroundings. This power loss also reduces the overall efficiency of the welder. It is quite obvious then that R_i should be made as small as possible under the circumstances.

Suppose we are talking about a 200 ampere welder. Under standard NEMA rating that transformer should be able to deliver 200 amperes into a 40 volt load. This represents a power output of 8 kilowatts. If the resistance is 0.1 ohm then using the power equation above we get a power loss of 4 kilowatts. This is much too high for the lost energy is equal to one-half of the useful arc energy. We can see then that the resistance of R_i must be on the order of a few hundreds of an ohm and that can be achieved by the use of heavy wire in the secondary.

Perhaps you will now recall that the watt is a unit of power and refers to a *rate* of energy release. In other words, the watt is equivalent to one joule per second, and the joule is a unit of *energy*. Then to determine the amount of *energy* that is lost in the form of heat in the welder, we must also include a time factor.

Summing up we can say that as long as current is flowing in the secondary, heat energy is being released, and the total amount of energy lost is directly proportional to the square of the current (I^2), directly proportional to the resistance (R_i) and also directly proportional to the time.

Now here is where the term "duty cycle" enters the picture. Since electrical power is relatively cheap, we can afford to lose a little in efficiency provided that the temperature of the welder does not become excessive. Then, too, we must be realistic. No regular welding operation is a continuous process over any lengthy time interval. The operator must change electrodes, set up his work and clean the weld bead. All this means that actually, the welder is called upon to deliver current for less than 100% of the time. During these "lay-off" periods, the welder will have a chance to cool down.

The welding industry has recognized this fact and as a result, the idea of duty cycle has been introduced. Welders are tested for consecutive ten minute intervals on the basis of so many minutes on and so many minutes off. 60% duty cycle simply means that the welder must deliver the rated current load for six minutes and then the load is removed for four minutes. The load is again applied for six minutes and removed for the next four. This process is repeated for four hours.

50% duty cycle would mean five minutes on and five minutes off, while a 20% duty cycle would have a two minute operating period and an eight minute cool-off period. Continuous operation is referred to as 100% duty cycle.

The duty cycle is determined by the type of service for which the welder is designed, and every reputable welder manufacturer lists the duty cycle rating of his machine as well as the rated current and open circuit voltage.

Suppose now that the designer is considering a welder for heavy duty industrial service. The National Electrical Manufacturers Association specifies a duty cycle of 60% for this type of service. The type of insulation used on the wires limits the maximum temperature rise that can be allowed. Again certain recommendations are provided by the various approval and testing agencies.

The temperature can be held down to reasonable limits by designing an efficient cooling system, or the designer can reduce the value

of R_i to a point where the energy loss in the machine is low enough for the machine to stay within the temperature limits.

In the last analysis the maximum allowable temperature rise is the final determinant for the proper value of R_i , and that temperature rise is affected by the type of insulation that is used, by the spacing of the winding and in general, the cooling provided, and, of course, the duty cycle.

It should also be pointed out that the ten minute test cycle is extremely important. Some people have the notion that the rated duty cycle of a machine is independent of the time period. They feel that as long as the overall operating period does not exceed the duty cycle percentage of the total on time, the machine is being operated within limits. This conception is completely erroneous. A thirty-six minute continuous operating period out of one hour does NOT constitute 60% duty cycle. The cycle of 60% on and 40% off must be completed within ten minutes or less.

While we are on this subject of duty cycle, we might examine what can be expected if the machine is operated at other than maximum rated load. Considering the fact that the heating is proportional to the square of the current, we can derive the following approximate equations:

$$I_n = I_r \sqrt{\frac{t_r}{t_n}} \quad (2)$$

$$t_n = \frac{t_r I_r^2}{I_n^2} \quad (3)$$

where: I_n is the current in amperes at the new duty cycle
 I_r is the current in amperes at the rated duty cycle
 t_r the rated duty cycle (expressed in decimal notation)
 t_n the new duty cycle

Working out an example or two, let's take a 200 ampere industrial rated machine (60% duty cycle) and see what the maximum current is that can be drawn continuously.

We use equation (2) and substitute the given values. I_r is 200 amperes, t_r is 0.6 (60%) and t_n would be 1 (100%).

$$\begin{aligned} I_n &= I_r \sqrt{\frac{t_r}{t_n}} \\ &= 200 \sqrt{\frac{.6}{1}} \\ &= 200 (.775) \end{aligned}$$

$\therefore I_n = 154$ amperes at 100% duty cycle (Ans.)

Since this is an approximate equation we can say that this machine could be operated at approximately 150 amperes at 100% duty cycle.

Taking another example:

Suppose we want to draw 275 amperes from this welder, what would be the duty cycle at this rating?

We now use equation (3) and substitute 200 amps for I_r and 275 amps for I_n and 0.6 for t_r and solve for t_n :

$$\begin{aligned} t_n &= \frac{t_r I_r^2}{I_n^2} \\ &= \frac{(.6) (200)^2}{(275)^2} \\ &= \frac{24000}{75625} \\ &= .32 \\ \therefore t_n &= 32\% \text{ duty cycle (Ans.)} \end{aligned}$$

Again since this is an approximate equation, 30% would be a safe figure.

You can see from these two examples that this same welder could very logically be rated as a 150, 200 or 275 ampere welder with duty cycle of 100%, 60% and 30% respectively.

It behooves the prospective user of an arc welder to inquire about the duty cycle rating of the welder besides the ampere rating, for you can see from the above discussion that the question: "When is a 200 ampere welder not a 200 ampere welder?" is not just a silly play on words.

CHAPTER XIII

ONE WAY STREET

In the welding industry, the term "rectifier" has taken on a special significance since the introduction of several welders using these devices.

A scientific definition of a rectifier would be that it is: "Any device that discriminates against bilateral current flow." In other words, any material that will conduct current better in one direction than the other can be called a rectifier and there are many such devices that fall into this category.

Sometimes it is advantageous to illustrate electrical phenomena with mechanical analogies. Using this analogy, the well-known check valve that is so frequently used in water or hydraulic systems is really the perfect rectifier. It will allow fluid to pass through in one direction but closes when the flow direction reverses.

In any electrical circuit a resistance is, of course, a bi-lateral linear device. By that it is meant that current flows equally well in either direction and that the current flow depends only on the magnitude of the voltage impressed on the circuit.

Suppose that we again perform a little experiment to clarify our point.

We are given a "little black box" completely sealed and having two exposed terminals, and it is our job to discover what it contains without opening the box.

We would start our investigation by applying voltage to the terminals and measuring the current flow, if any, through the box.

Now suppose we apply various voltages and plot the current for each voltage step. By using Ohm's law, we can easily find the resistance at each point.

If we discover that the resistance is the same no matter what the

voltage applied or in what direction, then we can be very sure that our "little black box" contains only a resistor.

If, however, we find that the resistance is not the same at every point, then we have what is known as a "non-linear" device. (The name comes from the fact that our current versus voltage graph would not be a straight line.)

Furthermore, if we find that the resistance varies over wide limits when the direction of current flow is reversed, then we can say that we have a rectifier in the box.

A perfect rectifier would have zero resistance in one direction and have infinite resistance in the other direction. This simply means that there would be no opposition to current flow in one direction, and that no current at all would be allowed to pass in the other direction.

Now the simplest rectifier, and perhaps the nearest approach to the perfect one, would be of the mechanical type.

If our little black box contained a simple, single pole switch and a little man trained to close the switch when current wants to pass through in one direction, and open the switch when the current direction is reversed—that would be a pretty good rectifier. Even though it may sound a little silly to talk about "a little man operating a switch," there are many rectifiers that operate on this principle. They are called "mechanical rectifiers" and generally consist of a vibrating reed or rotating contactor mechanism that is synchronized with the alternating current applied. The vibrator in your car radio is a device that operates on this principle.

Mechanical rectifiers are perfect in theory but are rather tricky to keep operating. They are subject to sticking, corrosion and arcing and burning and are therefore limited in their application.

But there are other types of rectifiers. Perhaps the most common type is the two element vacuum tube or diode. This is the basic vacuum tube invented by Fleming and known as the Fleming Valve. (It is interesting to note that vacuum tubes are still referred to as "valves" in most countries except the United States.) It consists of a cathode and an anode in an evacuated space. The purpose of the cathode is to liberate or release electrons. Usually, in small tubes, the cathode is of the thermionic type. Electrons are "boiled off" and form a cloud around the cathode.

Now, if we place another electrode in the vicinity of the cathode and charge it positively, it will attract the electrons and a current flow will take place.

If, however, the electrode is negatively charged, then, since like charges repel, the electrons will not be attracted and the tube does not conduct.

The ratio of forward resistance to reverse resistance determines the "goodness" of a rectifier, and on that score the diode (two element vacuum tube) is tops.

The diode, however, has its limitations, too. It cannot handle large currents that are usually demanded in industrial applications. The current carrying capacity of the diode is usually in the milli-ampere region. Higher capacities are, of course, available but the cost goes up out of all proportion as the current capacity is increased.

There are several other types of rectifiers. Certain chemical cells exhibit the characteristics of the rectifier. These cells have limited applications due to their general all-around messiness and maintenance difficulties.

Some special crystal structures of inorganic compounds are capable of doing an excellent rectifying job at very low currents, but at very high frequencies. The utilization of the microwave spectrum during the past few years has given a great boost to these "crystal rectifiers" (both natural and synthetic).

There is another type of rectifier that has been developed during the last two decades and stands the best chance of coming closest to that mythical "perfect" rectifier. This is the so-called "dry-disc" or metallic rectifier.

Progress since 1930 in this country and abroad has elevated this rectifier from a "limited use" status to a "universal" classification with unlimited horizons.

Dry-disc rectifiers make use of materials known as "semi-conductors." If we recall our general science lessons in introductory electricity, we were told that, electrically, all materials could be classified as either conductors or insulators. This infers that there is a sharp dividing line between the two classes of materials. Actually, this is far from the truth. We can only say that one material is a better conductor or poorer insulator than another material, and there are actually many materials that are border line cases.

One class of material of this type is made up of the "semi-conductors." These semi-conductors are very peculiar substances. They are perfect insulators at absolute zero where metals are generally "perfect" conductors. Yet at temperatures above absolute zero, they become better and better conductors. Generally speaking, they are also more or less photo-electric—perhaps we should say "photo-conductive" for the resistance varies to some extent with light falling on the material.

It was also discovered before the turn of the century that when materials of this type are placed in contact with a conductor in a sort of "sandwich" arrangement, the junction between the two materials shows very marked rectifier action.

In the past, three materials have been used to construct rectifiers of this type—copper oxide—copper magnesium sulfide—and selenium. Recently, germanium has been used successfully in small size units.

Copper oxide and the copper magnesium sulfide type have certain advantages for relatively low voltage applications. Selenium stands head and shoulders above the other two from the standpoint of maximum reverse voltage, efficiency, light weight and life, and it was not until a practical selenium dry-disc rectifier was developed that applications of dry rectifiers skyrocketed.

It should be remembered that all dry-disc rectifiers, although they may look alike, are not all selenium cells.

Perhaps we should look a little more closely at selenium itself before we go into detail on the construction of the rectifier cell.

Selenium is one of the 92 naturally occurring elements. It has a melting point of 220° C. and boils at 688° C. It is slightly less than twice as heavy as aluminum.

Chemistry books describe it as a gray, crystalline, semi-metallic appearing element of the sulfur group. Chemically, it does react similar to sulfur. It is quite difficult to refine to a high state of purity which is required for incorporation into metallic rectifiers.

To those people who have the notion that selenium is something new, perhaps the product of the atomic age, we can only say that the honor for the discovery and isolation of the element must go to Berzelius who published his findings in 1817. The great Swedish chemist discovered the element by heating the flue dust from one of the Swedish sulfuric acid works. For a long time this flue dust was the principal source of the relatively rare element.

Most modern selenium comes from the by-product of the electrolytic refining of copper. The mud that settles on the bottom of the refining cells contains appreciable quantities of silver selenide, and this compound is treated to free the silver and the selenium. Further treatment purifies the selenium for use in rectifier plates.

The actual amount of selenium used to produce a rectifier "cell" is relatively small. The layer is deposited on the base plate of aluminum or steel to a thickness in the neighborhood of 2 or 3 thousandths of an inch. The rectifying action does not take place in the selenium but rather at the boundary between the thin selenium layer and the front electrode which usually is an alloy of bismuth.

Now specifically, let us examine a selenium rectifier cell and see how it is put together and what the characteristics are.

First, let's start with the support plate or "back electrode." This plate, generally of aluminum or steel, serves to support the selenium and makes electrical contact with one side of the selenium layer. It has the other important job of radiating the heat produced during the rectification process. The thickness of the support plate is usually a compromise between mechanical strength and thermal conductivity.

The support metal should be free of surface imperfections and the rectifier manufacturer generally puts the material through a pretty rigid chemical treatment to insure cleanliness.

The next step is the deposition of the selenium layer. Theoretically there are many ways in which this thin layer of selenium can be put on the plate, but in actual practice, there are only three practical methods.

These methods are the "pressed powder" method, the "flow" (spinning) method and the "vapor deposit" method. There may be other methods, but the above three represent the accepted processes.

Remember the layer of selenium is very thin, roughly about .002 inches in thickness, and the selenium must be in an extremely pure state.

In the "pressed powder" method, the finely ground, purified, selenium is sprinkled on the metal plate and the bond is formed under pressure and heat.

The "spinning method" uses selenium in the liquid state and insures an even coating on the bare plate by flowing and spinning.

The third practical method being used to place the selenium on the support plate uses vapor deposition. The selenium, because of its

relatively low boiling point ($688^{\circ}\text{C}.$), can easily be vaporized and the vapor condensed on the support.

All three methods serve exactly the same purpose—to produce a thin, uniform layer of pure selenium on the support plate.

After some intermediate treatment, the front electrode is deposited on the selenium layer. This electrode is quite critical and must meet some rigid requirements. First of all, it must form a very good mechanical bond with the selenium. A pressure bond is ruled out because of the thinness of the selenium layer and the high local frictional temperatures that could be built up. That would leave only two other practical methods to get a good bond—electro-plating and metallic spray.

The electro-plating scheme cannot be used for various reasons, but the metallic spray deposit works well.

A very low melting point alloy generally composed of bismuth, cadmium and other metals, is sprayed on the selenium layer through proper masks, with conventional metallizing spray equipment.

This produces the grayish metallic coating on one side of the rectifier cell that is commonly mistaken for the selenium layer.

Now the forming process comes into play. By accurately controlled current flow through the cell and proper temperature, a microscopically thin layer of complex physical structure is formed between the front electrode and the selenium. This so-called “barrier layer” is actually the rectifying element. It allows electrons to move quite readily from the front electrode into the selenium but offers considerable resistance to electron travel in the opposite direction. Ratios of 1000 to 1 can be obtained in the way of forward to backward conductance.

The exact mechanics of the process is a pretty complex picture and cannot be discussed in a short summary such as this.

Suffice to say that conductance ratios of the magnitude obtained make an excellent practical rectifier.

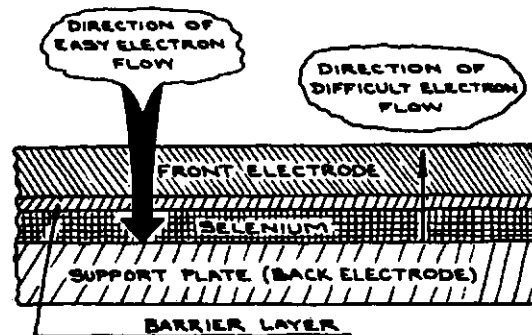

Fig. 32. Diagram of a selenium rectifier cell.

Now then, let's look at figure 32, a much enlarged cross-sectional view of a typical selenium cell. The various layers have been clearly identified and the direction of “easy” electron flow is indicated by the heavy arrow, while the “difficult” direction is symbolized with the light arrow.

If you are still not too familiar with the electron concept of current flow (minus to plus), you will have to say that electric current flows easily from the back electrode to the front electrode and very little current flows in the opposite direction, however, we'll stick to the electron concept.

Before we discuss the assembling of these "cells" into stacks, we must consider the "voltage rating" of the rectifier cell. I'm sure all people who have had any contact at all with rectifier devices have been exposed to the various voltage ratings of selenium cells. We talk about 26 volt cells, 30 volt cells, 33 volt cells, etc.

This rating simply indicates the maximum reverse A.C. (R.M.S.) voltage that the cell can withstand without rupturing the barrier layer. When this voltage puncture occurs, the ruptured spot is no longer a rectifier and it may burn itself clear and do no permanent damage to the cell—or it may destroy the cell entirely. Remember now, it is in the "reverse" direction where voltage puncture may occur.

The voltage rating of the cell is controlled somewhat by the processing and further by selection. The trend is toward higher and higher voltage ratings simplifying the series connection problem for higher voltage applications.

Of course, a cell can also fail by current overload in the forward direction.

Even though the cell may be a thousand times better conductor in the forward direction, it still has some resistance and thus heat is generated while current is flowing. Since the critical portion of the cell (selenium and front electrode) is very temperature sensitive, it becomes quite obvious that cooling and current density are two very important factors in rectifier life.

A further complicating fact is that selenium has a "negative temperature resistance coefficient." This high-sounding term simply means that, unlike normal metals, selenium becomes a *better* conductor as the

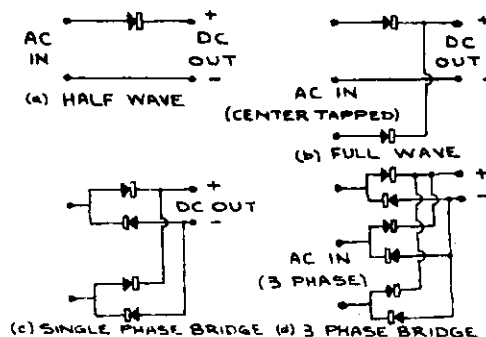

Fig. 33. Four common rectifier circuits.

temperature *increases*. Like all semi-conductors, selenium is a theoretically perfect insulator at absolute zero. So it becomes readily apparent that the hotter the rectifier gets, the more current it passes—the more current it passes, the hotter it gets. Cooling is therefore of prime importance.

Now that we have a pretty fair idea of how the selenium cell is made, let's see how it is assembled and used.

A rectifier "stack" consists of a number of "cells" assembled on an insulated bolt. Cells can be connected in series in order to secure higher operating voltages and connected in parallel to handle greater current.

In arranging these cells in series and parallel, connections are brought out for various rectifier configurations. See figure 33 for the four types in common use. Note that the half wave rectifier actually is a single unit (very much like a regular check valve) while the single phase full wave circuit consists of two units connected "back to back." A single phase bridge connection has four elements in the circuit while a three phase bridge rectifier, the most efficient, is composed of six units.

A notation is commonly used indicating the stack configuration. This notation consists of three numbers with the first indicating the type of connections (number of units), the second the number of cells in series and the last indicating the number of cells in parallel.

Thus when an engineer speaks about a 6-3-2 rectifier, he simply means that it is a three phase bridge rectifier composed of *six* arms each with *three* cells in series and *two* cells in parallel. The voltage rating on this stack is three times that of the single cell since there are three cells in series and the current rating (because of the two cells in parallel) is twice that of the individual cell.

Incidentally, the product of the three numbers gives the total number of cells in the completed stack, making thirty-six cells in the 6-3-2 bridge stack.

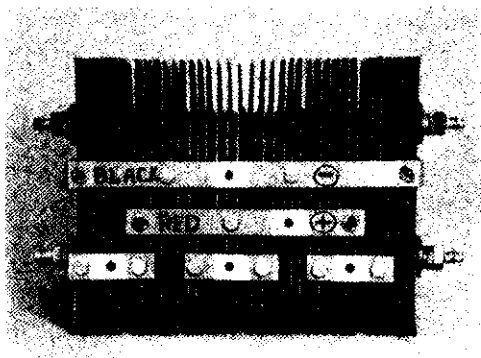

Fig. 34. Typical 6-3-2 selenium rectifier stack used in MILLER SR welders. Each plate consists of a single rectifier cell measuring 6 by 10 inches in area.

This, then, is the story of the selenium rectifier. A dry rectifier that is unsurpassed from the standpoint of efficiency, high reverse voltage per cell, minimum weight, long life and convenience.

CHAPTER XIV

HOW MUCH?

It has been said that in the field of scientific knowledge, you know nothing until you can measure.

In order to measure, two things are required—a standard and some method of comparing your measured quantity to the standard.

This may seem unnecessarily complicated but let me illustrate with a measurement with which we are all familiar—length.

Suppose we take a piece of wire and wish to determine its length. We say it is “so many inches” long. Just what do we mean?

First of all we are recognizing a certain standard of length—the inch. How this standard was defined is beside the point right now. It has been established and is recognized by most people.

Now when we say that the wire is so many inches long, we are simply implying that the wire is “that many times” as long as the standard that we call “the inch.”

Now what has all this to do with electricity?

In measuring the electrical quantities to which we so commonly refer, we must use the same fundamental techniques referred to before. The job is made a little more difficult because we are usually less familiar with the electrical terms than we are with the physical ideas of length, weight and time.

First of all, we must make absolutely sure that we know just what we want to measure. Too often ammeters are connected to measure voltage with disastrous results, and all too often it is due to a lack of knowledge of *what* is to be measured and a lack of understanding of the measuring process.

None of us would attempt to measure the *length* of a wire in *gallons*, but still we frequently do things as ridiculous as this by using the wrong instruments to measure electrical quantities.

Now let's investigate the process of measuring an electric current. Looking back at the basic fundamentals, we know that current is the "rate of charge flow." Since charge is measured in coulombs (and this would be analogous to quarts or gallons in measuring fluids), and the fact that "rate of flow" implies time, the basic unit of current ought to be the "coulomb per second." This simply means that a certain amount of electrical charge moves past a given point in one second. The name given to this "coulomb per second" measure is the "*ampere*."

So when we measure amperes we are not measuring pressure or energy or power or anything else but "rate of charge flow."

Unfortunately we cannot see the individual unit charges moving past a point, enabling us to determine the rate of flow directly, so we must resort to *indirect* methods of measuring current.

We have discovered that current manifests itself in several ways. First of all it produces a magnetic field. Secondly, it produces heat. Thirdly, it can bring about certain chemical effects or changes.

Once we know just what the relationship is between the current and the effect produced, then we can measure the effect and say that this is an indirect measure of the current.

The earliest method of determining current involved chemical effects. The amount of silver that was released from a silver nitrate solution per unit time was a measure of current. In fact, the standard definition of the international ampere still is based on this principle.

Obviously this is not a practical method of measuring current. It involves complicated experimental set-ups and could not be a convenient field method.

Well, how about the heat that is produced when a current exists in a conductor? The trouble here is that the heat produced per unit time is a measure of the *square of the current* (current multiplied by itself) and under certain conditions this may be desirable but usually it is not. This method has been utilized in the development of the so-called "hot-wire" ammeters. Here current is passed through a wire which becomes heated according to the square of the current and the expansion of the wire is then measured. This type of instrument is especially useful in measuring currents that are constantly changing in magnitude and direction. Obviously meters of this type are rather sluggish in operation and they tend to have scales that are crowded at one end.

You can visualize the theory of operation of meters of this type by imagining that you are measuring the amount of coal being shoveled into a boiler by measuring the steam pressure. Somewhat cumbersome and complicated, but it can be done.

Now when we turn to the magnetic effect of an electric current, then we find the ideal means of measuring current. The magnetic field that is produced by a given current is directly proportional to that current and of course a magnetic field can easily produce a mechanical displacement.

Perhaps the simplest way to show the theory of the galvanometer

(sensitive current measuring instrument) is to analyze the motion of a current carrying conductor in a steady magnetic field produced by a permanent magnet. Look at fig. 35 where we have set up a very simple experiment that illustrates the principle of the current measuring device.

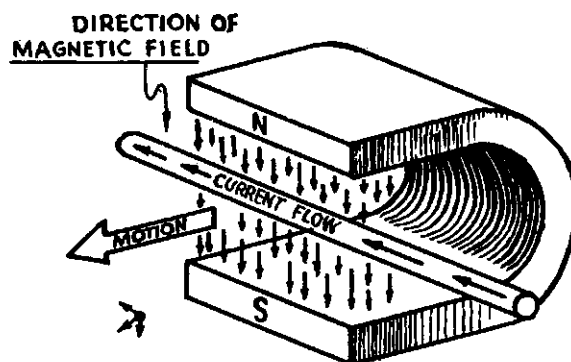

Fig. 35. A simplified diagram showing the action of a current carrying conductor in a uniform magnetic field.

The magnetic field produced by the current in the conductor interacts with the permanent magnetic field and a mechanical force is applied in the direction indicated by the arrow. If we now can measure the amount of displacement of the wire produced by the force, we can have an accurate measure of the current. The displacement is directly proportional to the force; the force is directly proportional to the magnetic field and the magnetic field is directly proportional to the current.

The motion of the wire can be detected in many ways. We may use a microscope, or perhaps attach a mirror to the wire and use a light beam projected on a scale.

Both of the above methods have been used successfully and many other ingenious schemes have been worked out to measure the movement of the wire and thus get an indication of the current flowing in the wire.

A more sensitive current measuring device results if we place a loop of wire in the permanent magnetic field and allow the interaction of the fields to produce a torque and thus rotate the loop (usually against the tension of a hair spring), and use the amount of rotation as an indication of the current flowing in the loop.

This is the famous D'Arsonval meter movement which is used so universally to measure *electric current*.

In order to produce a more uniformly concentrated field a soft iron core slug is fixed within the coil space and the pole faces of the permanent magnet are shaped to produce a radial magnetic field in which the coil can rotate. Note that the core slug, called the center pole, does not move and can actually be thought of as part of the field magnet.

The jeweled bearing supports, the zero-return hair spring and the pointer riding across the scale complete the assembly of the modern D'Arsonval meter.

Increased sensitivity is achieved by using a coil of many turns of

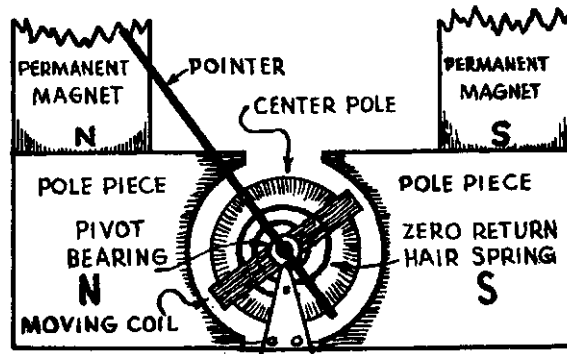

Fig. 36. Diagram of the basic D'Arsonval meter movement, without a doubt the most common current measuring principle.

fine wire instead of the single loop and making all moving parts just as light as possible. Incidentally, this explains why very sensitive meters are not made for portable use. The suspension is so delicate that slight jars would damage the instrument.

Fundamentally, then, the D'Arsonval meter is a current measuring device. Since Ohm's law gives us the relationship between voltage, current and resistance in a circuit, it becomes clear that the meter can be used to measure voltage, resistance or any other quantity which bears some relationship to current.



Fig. 37. Typical meter movement showing the various parts identified in figure 36.

Perhaps the most popular basic meter is the one containing a so-called "one milliampere movement." This simply means that the fundamental meter will indicate full scale with one milliampere of current.

If we now want to make the meter serve as a voltmeter, all we have to do is put a resistor in series with the instrument so that when the maximum voltage is applied, the current is limited to one milliampere by the resistance in the circuit.

If the meter is to serve as an ammeter, of higher capacity than the basic movement, a shunt is placed across the instrument so that the current divides with one milliampere (at full scale) going through the meter and the rest of the current by-passing the meter movement via the shunt.

Suppose we take a couple of actual examples and see how the theory works out.

We have a basic milliammeter which reads full scale with one milliampere of current. The resistance of the meter itself is 45 ohms. We want to convert this instrument so that it can be used as a voltmeter with full scale reading of 150 volts.

Using Ohm's law we determine the resistance that will limit the current to one milliampere at 150 volts.

$$R = \frac{E}{I}$$

$$= \frac{150}{.001}$$

$$R = 150,000 \text{ ohms}$$

Where: R = resistance (ohms)
E = voltage
I = current (amperes)

We know then that the total resistance of the instrument must be raised to 150,000 ohms. A series resistor of 149,955 ohms added to the resistance of the instrument will do the job. Now we have a voltmeter that will read 150 volts full scale. Using the same technique, other resistance values can be calculated to change the voltage range of the instrument to any practical value.

Converting the milliampere to a different current range becomes a somewhat more complicated calculation.

Suppose we want to use this same meter as an ammeter to read 10 amperes full scale.

We begin again with the basic meter movement and know that we must put a shunt across the meter to by-pass all except one milliampere of the total current. We find that in order to force one milliampere of current through the basic instrument will require a voltage of .045 volts, as calculated using Ohm's law as shown:

$$E = IR$$

$$= .001 \times 45$$

$$E = .045 \text{ volts (or 45 millivolts)}$$

The shunt that we are going to place across the meter then must have a voltage drop of .045 volts when all but one milliampere of the total current is flowing through it. Again using Ohm's law we get:

$$R_s = \frac{.045}{(10-.001)} = \frac{.045}{9.999}$$

$$R_s = .0045 \text{ ohms}$$

This, then, is the value of the shunt that must be used to convert the meter to 10 ampere instrument.

Once we understand the basic principles involved we can use a short-cut method to calculate the value of the shunts, without going through the step of calculating the voltage drops involved. We simply consider the fact that the shunt must carry 9,999 times the current that the meter can carry (full scale) and therefore the conductance of the shunt must be 9,999 times as great as that of the meter. Another way of saying the same thing is that the resistance must be $\frac{1}{9999}$ times that of the meter—(or simply $.0001 \times R_m$).

Applying this short cut we see that the value of the shunt would be:

$$R_s = .0001 \times R_m$$

$$= .0001 \times 45$$

$$R_s = .0045 \text{ ohms}$$

A little thought on this score will bring out the fact that the idea of meter conversions is really quite simple provided you understand the basic operating idea of the meter movement and have a nodding acquaintance with Ohm's law.

It is easy to see how these very handy multimeters such as shown in Fig. 38 can be assembled so that by a switching arrangement the meter can be used as an ammeter or voltmeter, and if equipped with a small source of voltage such as a battery, it can also be used as an ohmmeter.

So much then for the simple D'Arsonval movement meter using a permanent magnet for a magnetic field source. Obviously this type of meter can only measure direct currents, for as soon as the current reverses, the meter needle will tend to go in the opposite direction. If the needle could follow the pulses it would simply flip from one side to the other. A simple way out of the difficulty and still be able to measure alternating current is to use a rectifier and change the alternating current to D.C. and measure that. The rectifier needs to pass only one milliampere (in the case of the example cited above) and thus can be very small and compact. A.C. meters of this type are known as rectifier type instruments.

Fig. 38. A modern "pocket size" multimeter making use of a "one mil movement." Shunts, series resistors, rectifier and self contained battery enable the instrument to measure D.C. or A.C. volts, various currents and resistance in ohms.



There is no particular reason why the field magnet should be a permanent magnet. Why not use an electro-magnet to produce the field and then the field will reverse in step with the field produced by the moving coil. We could use this instrument to measure A.C. without using a rectifier.

This principle is incorporated in the dynamometer type of instrument which can measure both D.C. and A.C. Another interesting type of application of the dynamometer type of instrument is when one of the coils (usually the moving coil) is operated as a voltmeter across the line and the field coil (the stationary coil) is put in series with one side of the line and measures the current. The amount of needle deflection is then a function of the current times the voltage and we have a wattmeter.

Another type of meter that can be used with alternating current is the iron vane type of instrument. In this design magnetism is induced in a soft iron vane pivoted to the pointer. The iron vane interacts with the magnetic field, produced by a stationary coil, and causes the needle to move in proportion to the current in the stationary coil.

Summing up the characteristics of the practical and popular current measuring principles, there are two basic types, the hot-wire meter operating on the heating effect of an electric current and being fundamentally current squared instruments and then there is that group of instruments operating on the magnetic effect of an electric current. This last group can be sub-divided into the D'Arsonval type, the dynamometer type and the iron vane instrument.

One thing should be kept in mind. No matter how the scales may be marked and what the instrument is designed to measure, the basic movement is *current operated* and the maximum sensitivity depends

upon the number of turns in the operating coil and the elimination of mass and lightness of the suspension. A meter can always be changed to a lower sensitivity and higher ranges by using series resistors and shunts, but the sensitivity can never be made greater than that of the basic movement.

CHAPTER XV

ELECTRONS AT REST

We have pointed out in the last chapter that most electrical measuring devices make use of either the magnetic effect or the heating effect of an electric current. Whenever we deal with "static" problems involving charges and voltages, we must resort to other methods. It must be kept in mind that both the magnetic effect and the heating effect are phenomena associated with moving charges.

A look at basic theory about static electricity tells us that we can detect an electrical charge, regardless of whether it is at rest or in motion, by investigating the electric field. Remember: ". . . like charges repel and unlike charges attract. . . ." This principle can be used to measure voltage without current flow being involved. Voltmeters using this approach are called electrostatic voltmeters. They are not too practical for measuring relatively low voltages but are eminently suited for measuring extremely high voltages.

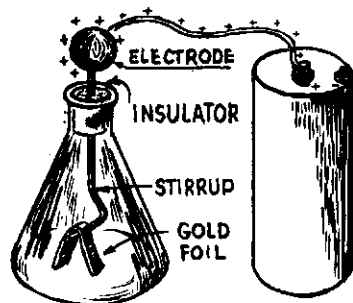

Fig. 39. Simplest form of an electrostatic voltmeter, the familiar gold leaf electroscope.

The basic operating principle of the electrostatic voltmeter is simply the principle of the old-fashioned "gold leaf electroscope." Figure 39 shows such an instrument that is nearly as old as the knowledge of electricity itself. It consists of an electrode terminating in a "stirrup" at its lower end. This stirrup supports a delicate strip of gold foil at its midpoint with the two ends hanging vertically (when the electroscope is uncharged). The insulator serves to isolate the electrode while the purpose of the bottle is simply to shield the delicate gold leaves from air currents. Incidentally, the only purpose for using gold leaf is the fact that gold can be rolled to thinner sheets than any other metal. The gold leaf used in electroscopes is unbelievably thin and delicate.

Now let's see how the instrument operates. Suppose the electrode is connected to a positive charge as shown in figure 39. Since the electrode and the gold leaves are made of conducting material, the charge will distribute itself throughout the electrode and gold leaves. Note, then, that the two gold leaves (actually only one gold leaf folded in the middle) carry the same charge. Since we know that like charges repel, we should expect the two leaves to diverge, and this is exactly what happens. The amount of divergence will depend upon the magnitude of the charge. When the electroscope is discharged, gravity pulls the leaves back into a vertical position.

It should be noted that although we have used a positive charge for our illustration, the action of the electroscope is exactly the same with a negative charge.

There are many variations of the operating principle, but the basic idea is always the same. It is interesting to note that the electroscope is a single terminal type of instrument, a characteristic of electrostatic devices. Remember now, we are not concerned with current flow and as a result, we do not need a complete circuit in the same sense as we have in current electricity.

Perhaps the most common measuring instrument using electrostatic principles (and therefore a purely "voltage operated" device) is the cathode ray oscillograph. Due to the wide use and almost unlimited application we should take a close look at this versatile electrical measuring instrument.

The heart of the oscillograph is the familiar cathode-ray tube originally developed by the German physicist, Braun.

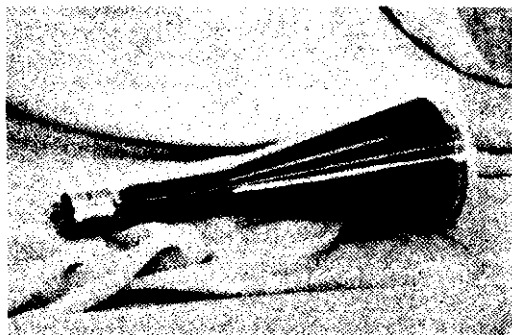

Fig. 40. Typical modern cathode-ray tube. This tube has a 5" screen.

It consists of a highly evacuated flask containing a fluorescent screen on one end and an electron gun at the other end. In between we find the deflecting electrodes.

To gain a complete understanding of the operation of the cathode ray tube, let's consider each part separately.

Perhaps the easiest way to start is with the fluorescent screen. There are certain chemicals called phosphors that have the peculiar characteristic of glowing with a characteristic color when struck by radiation such as ultra-violet rays or x-rays, or when struck by fast moving particles such as electrons or other sub-atomic particles.

The most common example of this phenomenon can be seen in the ordinary fluorescent light tube. The basic idea here is that a mercury arc is established between the end electrodes of the tube and this arc produces radiation that is extremely rich in ultra-violet (black light) rays. The ultra-violet rays strike the inside coating of the fluorescent tube causing the phosphors in the coating to glow with their characteristic colors. The manufacturer can control the color of the light given off by the phosphor by using different phosphors or mixtures of various phosphors.

Getting back to the cathode-ray tube we find that the end of the tube which constitutes the viewing screen is struck by fast moving electrons. It is easy to see now that if a small concentrated beam of electrons is allowed to strike the viewing screen, a small spot of light will indicate the point of impact.

Now let's examine the other end of the tube. Here in the narrow neck of the "bottle" we find the electron gun. The purpose of the electron gun is to produce a fine, high speed stream of electrons and direct that stream toward the fluorescent screen at the other end of the tube.

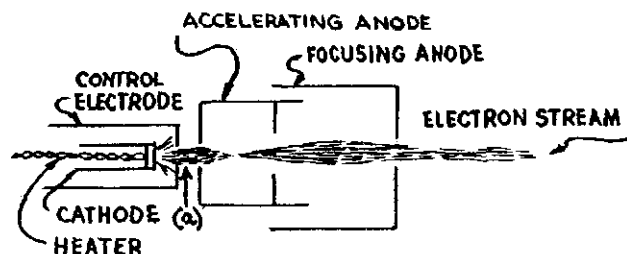

Fig. 41. Simplified diagram of the electron gun of the modern cathode-ray tube.

Before we worry too much about how those electrons are going to get to the other end of the tube, keep in mind that the tube is highly evacuated. As a result, there are no air molecules that the electrons can bump into and therefore there is nothing to stop the electron stream from reaching the other end of the tube and striking the fluorescent screen.

The electron gun consists of a heated cathode which serves as the source of electrons, a control grid and two accelerating anodes, as shown in figure 41. The purpose of the control grid is to control the number of electrons that are allowed to escape through opening (a)

and thus serve as an intensity control for the electron beam. Allowing more electrons to squirt out of the electron gun, increases, obviously, the number which will strike the fluorescent target and thus increase the brilliance of the light spot on the screen.

The purpose of the first and second accelerating electrodes (which are positively charged with respect to the cathode) is to speed up the electron beam and also to focus the beam so that as small a spot as possible is formed at the viewing screen. The electrode arrangement constitutes what is commonly known as an electron lens, and in action is similar to the familiar optical lens.

It is impossible here to go into the theory of electron lenses in this brief discussion but as long as we keep in mind the basic fact that like charges repel and unlike charges attract and that the electron stream is composed of negative particles, it can be seen how the various electrodes accomplish their purpose.

Now we come to the most important electrodes of the cathode ray tube, the deflection plates.

Just after the electron beam leaves the accelerating anodes it passes between two sets of parallel plates on which voltages may be placed.

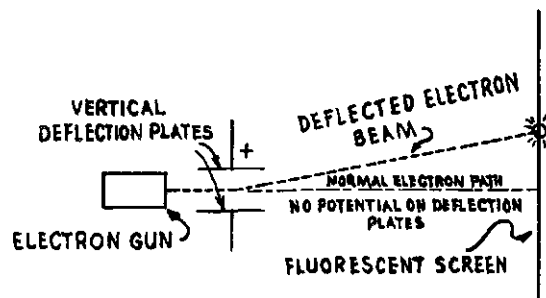

Fig. 42. Diagram showing the electron path in a cathode-ray tube.

Turn to figure 42 and consider what will happen if a voltage is placed on one set of plates as shown. Keeping our fundamental law in mind we see that the beam is deflected in an upward direction. If the voltage on the plates varies rapidly, the spot will be shifted back and forth. Due to the persistence of the screen glow and the persistence of vision, we see a vertical line on the oscillograph screen. The length of the line is obviously a measure of the voltage placed on the plates.

If we now add another set of deflecting plates at right angles to the first set, we can deflect the beam right and left and then we have a rectangular coordinate system that will enable us to move the spot to any position on the screen by the proper application of voltages to the two sets of deflecting plates.

Unfortunately, the voltages required to cause appreciable deflection are quite large so in order to increase the sensitivity of the instru-

ment the input voltages to be measured are generally connected to the deflecting plates through amplifiers. This usually limits the cathode ray oscillograph to the observation of rapidly changing voltages which, however, is not a serious limitation.

But the amplifying system and the use of the oscillograph is another subject that we will discuss at some future date. The point to remember is that the cathode ray oscillograph is truly a *voltage operated* device and in this respect differs from the instruments described before which were current operated devices.

CHAPTER XVI

WHEN TROUBLE STRIKES

Electrical designers, generally speaking, are striving to make all electrical devices simpler to operate and more reliable and fool-proof. We have many machines today that operate complete, complex, cycles at the simple command of the operator in the form of a push of a button. When everything is functioning the way the designer intended, the user experiences no difficulty. Should some component fail to operate correctly, then the entire cycle is upset and an understanding of the basic principles is required to restore the correct cycle of operation. It is here where the informed operator or the service man comes into the picture.

Let's take a simple illustration of trouble-shooting on a machine that is common to the American scene—the automobile.

Even though the modern motor car is a marvel of complexity, it still is composed of many component parts that do a simple operation at the right time.

Suppose this morning, when you stepped on the starter button of your car, nothing happened. Either you called a mechanic and gave the problem no further thought or you tried to diagnose the difficulty and clear the fault.

In either case, you or the mechanic solved the problem by the process of elimination. Since the starter did not turn over there were only two conclusions that could be made. Either the starter motor was defective or it was not getting electrical power. Knowing from experience that electric motors are pretty reliable devices our first logical assumption would be that the starter motor was not getting the required electrical energy.

Since the source of this energy is the battery this was the first item to be checked. The fact that the battery also supplies power to the lights and horn, prompted you to try both of these components. If they did not operate you called the garage and said: "My battery has gone dead."

If the horn and lights had worked, your suspicion would have been directed to the starter switch and cables and last to the starter motor itself.

Now all this takes no great mechanical or electrical skill—simply a basic understanding of the principles involved. True, you no doubt would still require the services of a mechanic to *repair the device* but a knowledge of basic principles allowed you to isolate the defect.

Of course if this happened to you many times, you would draw on your past experience and it would be simpler for you to locate the trouble—then you would be an “expert.”

Now what has all this to do with reading a circuit diagram?

Simply this: In order to have an understanding of the basic principles involved you must receive information from someone else and then the problem simply becomes one of communication and the circuit diagram is simply a shorthand method of explaining the method of interconnecting electrical components.

It is important to remember *that all machines ever developed are simply a combination of many simple devices*. This holds true for the most complex electronic calculator, the largest radar or T.V. installation or the most elementary electric bell circuit.

The circuit diagram is simply a description of how these component parts are interconnected to make up the complete electrical device.

There are three general types of circuit diagrams that are in common use—the pictorial, the block, and the schematic. Frequently a clearer story can be told by combining two or even three of the basic types into a single diagram.

The pictorial diagram is perhaps the simplest to read but has its limitations in that it becomes very confusing if too many component parts are involved. The pictorial diagram also suffers when an attempt is made to show the correct location of parts. For illustrative purposes we show in figure 43 a simple circuit of a dry cell, a knife switch and a light bulb. There is no chance for a mistake or a wrong interpretation of this circuit diagram. Even a youngster, without any knowledge of electricity, could follow the diagram.

The diagram, however, is correct only as long as the physical characteristics such as shape, size and appearance of the component parts correspond to the picture. For example, suppose you do not have a knife switch as shown in the diagram, it would take some knowledge to infer that another type switch would serve as well. To the experienced individual the shape of the dry cell would make no difference, but to the novice it might seem important.

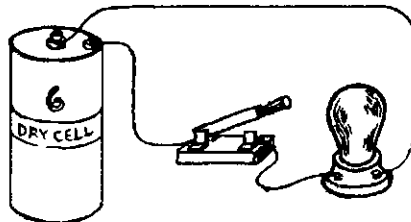

Fig. 43. Pictorial wiring diagram of a simple electric circuit.

Now, admittedly, the pictorial diagram is excellent from the standpoint of identifying component parts.

The pictorial, therefore, has a great appeal to the uninitiated but leaves much to be desired from the functional standpoint.

Where the emphasis is on function, we go to the other extreme, the block diagram. Here, no effort is made at all to identify the component parts, but the functional component is simply represented as a block and labeled. Figure 44 shows the same circuit as before but this time in the form of a block diagram.



Fig. 44. Block diagram of the same circuit as represented in figure 43.

Note that emphasis here is entirely on the function of the circuit. It simply tells us that a battery is connected to a lamp through a switch. The switch obviously serves to control the energy flow from battery to lamp and nothing more can be inferred from the diagram.

Notice that there is no indication as to the specific type of switch to be used; nor of the size, shape, and rating of the battery; nor is anything indicated about the lamp characteristics.

The block diagram is extremely useful where a general idea of the operation of the completed assembly is desired. The advantage of a block diagram is that it eliminates all detail that may serve to confuse the main issue, system operation.

Thus we generally find that complex electronic circuits such as those of computers, extensive audio systems, radar and many others, are generally represented at the earliest stage of development by block diagrams.

A block diagram is functional, pure and simple, and any effort to read component details from it, is useless.

It would now seem that a combination of the two diagrams would be the ideal solution. This is realized in the true "schematic diagram." Here we use symbols for the various component parts and we show all connecting wires. You might say that the schematic diagram is a shorthand method of writing a complete circuit description showing both functions and individual circuit components. The schematic of our simple circuit would look like that shown in figure 45. Usually the parts are identified by a code as shown and more information can be gleaned from this circuit than from the other two previously discussed.

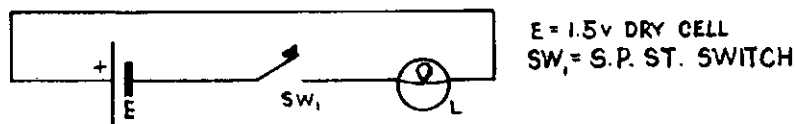
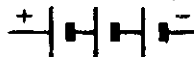

Fig. 45. Schematic diagram of the same circuit as shown in figures 42 and 43.

Note that the battery, identified by E (or some other way) is described as a 1.5 volt dry cell. The electrical operation of the circuit is not dependent on the physical size of the battery at all and the symbol



is the standard accepted marking for any type or size of battery cell. If the battery is made up of several cells, the symbol is like this:



This would be a 3 cell battery. Now of course when high battery voltages are encountered (more cells), then we generally use a symbol such as the following and indicate the voltage of the complete battery right on the diagram:

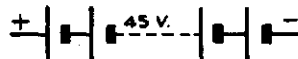

The symbol for the switch may be as shown in figure 45 but some designers use a circle with a cross in it to indicate a toggle switch, thus:



Generally, the abbreviation SW or S is used to label the switch, with numbered subscripts used where more than one switch is shown.

You will note that some of the symbols, for example the one for the lamp, show their derivation from the pictorial diagram. Many of the symbols can be recognized quite easily and generally speaking, schematic diagrams are not difficult to follow.

As pointed out several times, a circuit diagram, no matter how complex, is simply a combination of basic components. The difference between the block, pictorial and schematic type of diagram is only in the method symbolizing those basic components.

For the remainder of this discussion we are going to consider only the schematic type of diagram and we shall concentrate on the ability to recognize the various components.

Generally speaking, two popular systems of symbols grew up like Topsy during the early years of electrical development. The radio and electronics boys used a certain system while the power and control people used a system that differed markedly in certain respects. It is obvious that unless some standardized system is available, diagrams could become very confusing and meaningless.

For example, power engineers have always represented a contact (normally open) as shown in figure 46a. Yet the radio engineers used the same symbol to represent a capacitor. On the other hand, the power engineers always represented (and some "die-hards" still do, including MILLER engineers when we forget ourselves), a capacitor with the symbol shown in 46b. There are many similar examples where one symbol might represent several different components, depending entirely on what scheme you were using. Then to add still more confusion to the situation, many engineers and authors used symbols of their own.

The need for a standard system was recognized many years ago but it was not until shortly before World War II that a concerted effort was made to develop a unified system.

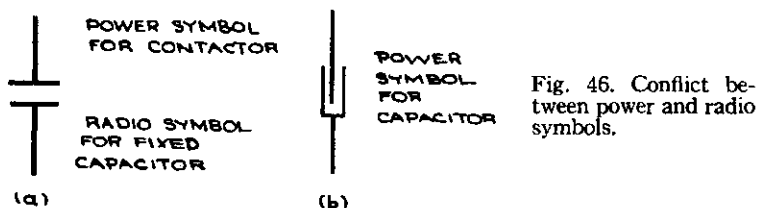

Finally, through the efforts of the American Institute of Electrical Engineers, the Institute of Radio Engineers and other interested organizations, a standardized system was developed. The American Standards Association* has published several pamphlets on electrical symbols, and if any doubt exists as to the proper symbol to be used, this organization is generally accepted as the arbiter.

Joint industry conferences are held periodically at which time action is taken on changes in symbols or recognition of new symbols.

It might be of interest to see how the one example of conflict between the two schemes of symbols, mentioned above, was resolved. The radio engineers and power engineers both gave up their symbol for the capacitor and adopted a new and different one as shown in figure 47a.

Fig. 47. New standard symbols for capacitors.

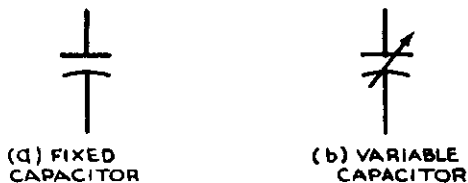

This, then is the universal symbol for a capacitor, irrespective of size or type. The symbol does denote that the capacitance of the capacitor is fixed. To show that the value of capacitance is continuously variable (such as a tuning condenser) a slanted arrow is drawn through the symbol as shown in figure 47b. Concessions of similar nature resulted in a unified system from which we have taken some of the most useful symbols and have listed them with brief explanatory comments where needed.

WIRING

A solid line represents an electrical connection. Where mechanical linkage must be shown, a dashed line is used. If the dashed line is a continuous line and encloses a definite area, it is an indication that this area is electrically shielded. If crossing of two wires does not show a dot at the junction, then these wires are not connected. A dot at the

*American Standards Association, 70 East 45th Street, New York 17, New York.

junction shows an electrical connection. Wiring lines are generally drawn as straight lines and at right angles. figure 48 illustrates these points.

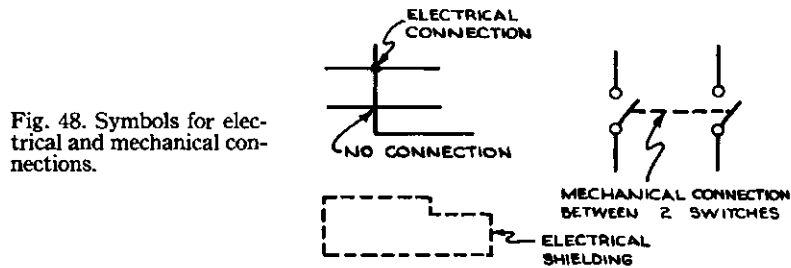

Fig. 48. Symbols for electrical and mechanical connections.

SWITCHES

A switch element is shown simply as a break in the wiring with one end of the lead ending in a slant line. Sometimes small circles are used, the circles representing terminals.

A pushbutton switch always uses the terminal symbols and whether the button is normally open or closed can readily be seen. Circuit breaker symbols as shown are used frequently.

Of course there are many variations of these basic symbols to indicate certain types of switches. In the examples in Figure 49, a limit switch, a foot switch and a temperature operated switch are illustrated.

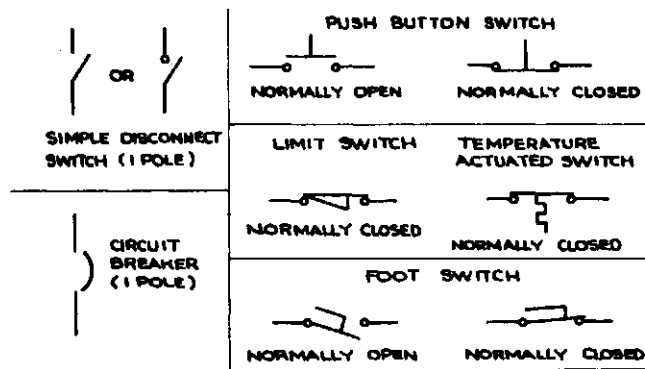

Fig. 49. Circuit breakers and switches.

CONTACTORS

Contactors sometimes cause confusion in circuit diagrams for the simple reason that although the contactor coil and the contacts are a single mechanical package, the electrical functions may place the operating coil in one part of the circuit and the actual contacts may be scattered over different parts of the circuit. The operating coil is represented simply as a circle **WITH AN IDENTIFYING LEGEND**, and the standard contact symbols are used with legends to tie them to the operating coil. It is easy to overlook some contacts in those cases where a lot of contactors and relays are involved, and recently an effort was made to simplify the situation. This simplification consists of numbering, along the edge of the diagram, the lines that contain contactors and then indicating in parenthesis right at the contactor coil, the numbers of the contacts operated by said coil. To aid still more, the normally closed contacts are underlined.

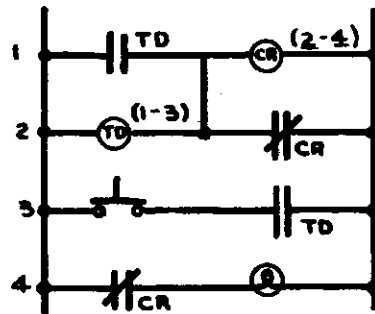

Fig. 50. Sample circuit.

You will note how this system works out by studying figure 50 carefully. Note that operating coil CR has two sets of contacts associated with it. These contacts are located at line 2 and line 4 and since the numbers are underlined, the contacts are normally closed. Relay TD also has two sets of contacts in the circuit but these are normally open and are located at line 1 and line 3. Also notice the normally closed pushbutton switch at line 3 and the lamp at 4. (Ed. Note: Don't try to figure out the operation of the circuit. It is purely fictitious and is intended only to show the symbols.)

RESISTORS

The general symbol for a resistor is a rectangular frame with the identifying legend within, or adjacent to, the rectangle. The older symbol, the broken line, is also a standard symbol and is commonly used. There are, of course, many variations to show the type of resistor. For example, a continuously variable resistor is shown with an arrow slanting through the rectangle while a potentiometer is shown with a

connection to an arrow for the third terminal. Generally speaking, if it is important to show whether the resistor has leads or terminals, the standard convention is used. Figure 51 clearly shows the various ways in which resistors are represented.

Fig. 51. Symbols representing resistors.

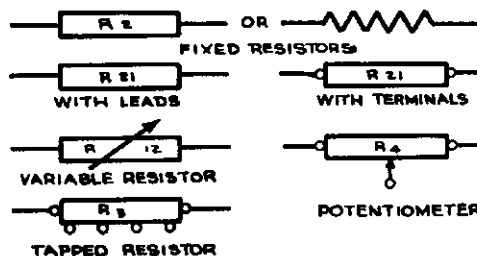

TRANSFORMERS AND REACTORS

Although two types of symbols are recognized, the one showing the completed loops is the more popular (perhaps it has been in use longer) although the other type is easier to draw. If the coil stands alone it is a reactor, but if it appears adjacent to another winding, then the symbol represents a transformer. If the inductor is to be identified as being associated with a magnetic core, then two or three parallel lines are drawn parallel to the axis of the loops or scallops as shown in figure 52.

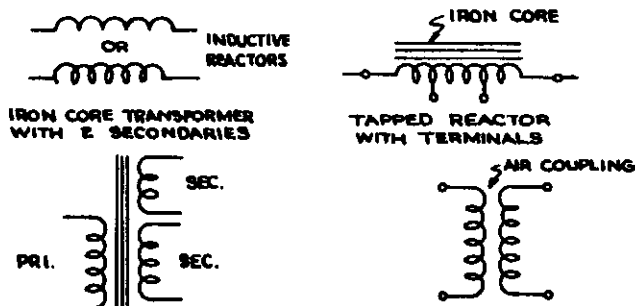

Fig. 52. Transformer and reactor symbols.

This gives us the general symbols that are used in drawing schematic diagrams of welding machines and associated control circuits.

CHAPTER XVII

HIEROGLYPHICS

Since the previous article in this Basic Electricity series concerned itself wholly with the electrical symbols and diagrams, let's now put the series to test by actually analyzing, step by step, the schematic circuit diagram of an actual welder.

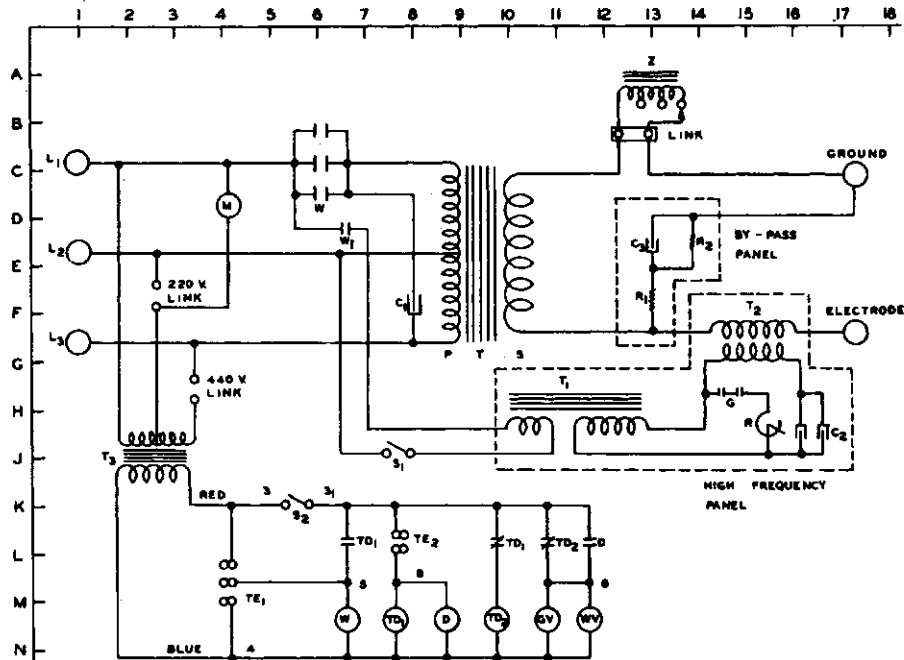

Fig. 53. Schematic wiring diagram of a MILLER inert gas welder. ("A" model.) The letters along the left side and the numbers along the top serve to locate the various parts discussed in the text.

We have taken the circuit diagram of a MILLER model 203-A "Heliarc" arc welder and placed over it an imaginary reference grid whose coordinates appear along the margins. This will make simple, positive, identification of all points on the diagram possible. Of course, we should also have the identification key for this diagram but since space is limited and we are going to go over the diagram, we can dispense with it. So now, let's go.

Along line 1 at C, E and G you will find the line input terminals marked L_1 , L_2 and L_3 .

Since this is a dual voltage machine we must make sure that the proper terminals are used for the line connections. L_1 is the "common" terminal. One side of the power line always goes to this terminal. If the machine is to be operated at 220 volts (single phase, 50/60 cycle A.C.), the other side of the power line will connect to terminal L_2 . If the machine is operated on a 440 volt line then terminal L_2 is not used and the one side of the line ties to terminal L_3 .

We note a "220 V. link" at F3 and a "440 V. link" at H4. We also note that M (at D4) and T_3 (at J2) are connected to L_1 . M represents the cooling fan motor and T_3 is the control transformer.

Now if the 220 V. link is installed and the link terminals shorted, note that 220 V. are applied to the fan motor and one-half of the control transformer primary is also connected to the line. If operation on the 440 volt line is desired, then the 220 volt link must be removed and the 440 volt link put into position. Now note that the primary of the control transformer is acting as an auto-transformer and even though 440 volts are applied to terminals L_1 and L_3 , the fan motor is supplied with 220 volts because of the step-down action of the primary T_3 .

As we follow the lead from terminal L_1 along, we find three normally open contacts, labeled W, connected in parallel, at location C6. These are the primary contactor contact points. The three terminals are paralleled simply for greater current carrying capacity. Near this location is another contact labeled W_1 which is the "interlock" contact of the same line contactor. The operating coil for line contactor is labeled W and appears at N7. When the operating coil becomes energized the W contacts close and power is applied to the main transformer T. C_1 at F8 represents the power factor correction capacitor. Note that it operates at 440 V. no matter whether 220 V. or 440 V. are supplied to the welder. The interlock contact W_1 closes the circuit to the high frequency transformer T_1 (provided the high frequency switch S_1 is closed), starting the high frequency unit. Note that the primary of T_1 always operates on 220 volts and operation is initiated with the closing of W_1 .

The high frequency panel consists of T_1 , the high frequency power transformer, G representing the spark gaps (two gaps in series), two condensers labeled C_2 (connected in parallel), the H.F. control rheostat R and the air core coupling transformer T_2 . The by-pass panel consists of capacitor C_3 and resistor R_2 across the capacitor and resistor R_1 in series with it. The purpose of the by-pass panel is to keep the high frequency energy, developed across the terminals of T_2 , from going through the secondary S of the main transformer T. The reactor Z,

located at B13, is tapped and connected in series with the main output ground or work lead. This reactor serves to limit the output of the welder for the lower ranges.

The control panel consists of various relays and contacts and is served with 110 volt power from transformer T_3 .

Now for the actual operation of the circuit. Closing S_1 the high frequency switch, prepares the HF unit for operation. Note, however, that the HF unit will not start until the main contactor is closed. Turning switch S_2 applies 110 V. power to the control circuit. Contacts TD_1 at L10 and TD_2 at L11 are normally closed applying power to operating coil TD_2 at N10 and also operating (opening) the gas valve GV and water valve WV. Coil TD_2 is the operating coil of a time delay relay (post flow of gas and water) and this relay begins to function. After about a 12 to 15 second delay, TD_2 contact at L11 will open and the gas and water valves GV and WV will shut off. Now the actual operating cycle is ready to begin.

The foot switch (not indicated in diagram) is connected to terminals TE_2 and when the operator closes the foot switch, terminals TE_2 at L8 are closed. This activates coil D (N9) which instantly closes contact D (L12) and operates the gas valve GV and the water valve WV. Note that contact D does the controlling of the valves because contact TD_2 at L11 is still open since coil TD_2 (N10) is energized, holding the contacts open.

The operation of a time delay relay may be somewhat confusing at times—especially if it is of the normally closed variety. A diagram of the operating cycle of TD_2 as shown below should clarify the operation.

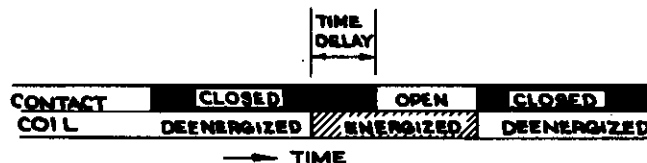

Fig. 54. Diagram of time sequence of a time delay relay.

At the same time that coil D is activated, coil TD_1 , the operating coil of a 1-1/2 to 2 second time delay relay is energized. After this short delay, TD_1 at L7 closes and the main contactor coil W pulls in the main contacts W and W_1 discussed previously. This starts the welder and at the same time the high frequency. Normally closed contact TD_1 at L10 opens at the same time and coil TD_2 at N10 now becomes deenergized and contacts TD_2 at L11 again close. Now as long as the foot switch remains on both, contact D (L12) and TD_2 (L11) remain closed.

Suppose now that the operator opens the foot switch and thus breaks the circuit at TE_2 . The immediate effect will be that coils TD_1 (N8) and D (N9) will become deenergized. Immediately contact TD_1 at L7 and contact D at L12 will open. Power is shut off from the main

transformer because coil *W* is deenergized and the main contacts open. Contact TD_1 (L10) will again close, energizing coil TD_2 , keeping the gas and water valves open until contact TD_2 at L11 opens to shut down gas and water.

All this, we realize, sounds highly complicated but it really isn't. A little patience and pointing out each reference on the diagram will make this—and all circuit diagrams—simple as pie.

APPENDIX

Author's Note: About midway through the series of "Basic Electricity" as it appeared in Memco-News a quiz was inserted to serve as a self check for the reader. The test was designed to emphasize some of the more important points that had been covered at that time.

PART "B"

This part of the quiz consists of "true and false" statements. Place either a "T" or "F" in the spaces provided.

1. Inductive reactance is encountered only in A.C. circuits.
2. Ohm's Law states that the current in any circuit is directly proportional to the resistance.
3. A changing magnetic field is always accompanied by an electric field.
4. Coulomb's Law deals with magnetism.
5. Magnetic forces are the same as electric forces.
6. All electric generators (rotating type) are fundamentally A.C. devices.
7. In electromagnetic induction, the time rate of cutting the lines of force governs the induced voltage.
8. A purely inductive circuit would have zero power factor.
9. In a capacitive circuit, the current is lagging behind the voltage.
10. Transformer cores are laminated to minimize induced eddy currents.
11. The symbol usually used for impedance is Z.
12. Protons are more easily moved than electrons.
13. The "ampere" is equivalent to coulomb per second.
14. The modern electron theory is usually credited to Benjamin Franklin.
15. Heat is actually the energy of atoms and molecules in motion.
16. Energy is "the ability to do work."
17. In 60 cycle A.C. current, there are 120 intervals each second, where the current is zero.
18. The relationship between the electric and magnetic fields was first discovered by Oersted.
19. When the power factor of a circuit is zero, no current is flowing.
20. When a capacitor is connected in an A.C. circuit, electrons actually flow through the dielectric.

1.	6.	11.	16.
2.	7.	12.	17.
3.	8.	13.	18.
4.	9.	14.	19.
5.	10.	15.	20.

PART "C"

This is a completion test. The idea is to complete each sentence by filling in the correct word.

In the field of electricity, one of the most important points is to know the units that are used to measure various electrical quantities. We should know that current is measured in (1)_____ while potential units are (2)_____. The watt is the unit of (3)_____, while the watt-hour measures (4)_____. Resistance is measured in (5)_____ while the (6)_____ is the unit of conductance. The farad is the measure of electrical (7)_____ and the henry unit of (8)_____.

Power factor is expressed in (9)_____. Inductive reactance is measured in (10)_____ and for a given coil increases with the (11)_____ of the A.C. power. The measure of quantity of charge is the (12)_____, a name that is not in common usage.

Prefixes are frequently used to make the units more manageable, the one which means 1000 is (13)_____, the one measuring 1/1,000,000 is (14)_____, while the one representing 1/1000 is (15)_____.

PART "D"

This part of the quiz consists of six problems to be worked out.

1. The resistance of an electric heater designed for 220 volt operation is 11 ohms. At the rate of 6 cents per kilowatt hour, how much would it cost to operate this heater continuously for an 8-hour day?

2. An arc welder is being used with a welding cable (including ground lead) 200-ft. long. The welding cable is 1/0 whose resistance is 0.1001 ohms/1000-ft. What voltage drop will be encountered in the cable while welding at 225 amperes?

3. How many light bulbs, each having a 200 ohm resistance, can be connected in parallel with each other across the two wires of a 100 volt lighting system if the maximum allowable current is 10 amps?

4. One horse power is equivalent to 746 watts. The Onan engine used in the MILLER AEA-200-L develops approximately 7.3 h.p. while throttled back for 60 cycle power generation. At 77% efficiency, how many amperes can be drawn at 220 volts?

5. What is the 60 cycle impedance of a coil having a resistance of 100 ohms and an inductance of 0.318 henries?

6. A welder draws 116 amperes at rated load from a 220 volt line. The rated input power is 15 KW. What is the power factor at rated load?

1. _____
2. _____
3. _____
4. _____
5. _____
6. _____

To determine your score for this quiz, check your answers with the correct answers below. Part "A" is scored 2 points for each correct answer. Part "B," one point for each correct answer. Each correct answer in part "C" counts 2 points, while a correct answer for each problem of part "D" counts 5 points.

A score of 70 or above is considered "passing." If you score above 92, you can give yourself an "A," while a "B" drops to 85. "C" rates from 78 to 84 while a 70 to 77 has to settle for a "D."

Answers to Basic Electricity Quiz

PART "A"

- | | | | |
|--------|--------|--------|---------|
| 1. (a) | 4. (a) | 7. (b) | 10. (a) |
| 2. (d) | 5. (d) | 8. (b) | |
| 3. (b) | 6. (a) | 9. (b) | |

PART "B"

- | | | | |
|------|-------|-------|-------|
| 1. T | 6. T | 11. T | 16. T |
| 2. F | 7. T | 12. F | 17. T |
| 3. T | 8. F | 13. T | 18. T |
| 4. F | 9. F | 14. F | 19. F |
| 5. F | 10. T | 15. T | 20. F |

PART "C"

- | | |
|----------------|---------------|
| 1. Amperes | 2. Volts |
| 3. Power | 4. Energy |
| 5. Ohms | 6. Mho |
| 7. Capacitance | 8. Inductance |
| 9. Percent | 10. Ohms |
| 11. Frequency | 12. Coulomb |
| 13. Kilo | 14. Micro |
| 15. Milli | |

PART "D"

- | | |
|---------------|-----------------|
| 1. \$2.11 | 2. 4.5045 Volts |
| 3. 20 Bulbs | 4. 19 Amps |
| 5. 156.1 Ohms | 6. 58.7% |



FORM: BE-8-79 (10-82)

LITHO IN U.S.A.